

STRAIGHT FROM THE HEARTLAND

2023 - 2024



**DEALER  
CATALOG**

**800-798-1968**  
**SHIELDAG.COM**



# Quality Agricultural Equipment

## Manufacturers of:

V-Blades • Sweeps • Chisels & Spikes • Disc Blades • Drill Discs & Hoe Drill Points  
Related Tillage & Planting Hardware • Fertilizer Knives • Shanks • Coulter Blades • Crop Savers  
Precision Planting Equipment • Conservation Ripper Points • Strip Till Points • Fertilizer Row Units

## Distributors of:

Belted Grain & Fertilizer Conveyors • Salt & Material Handling Conveyors • Seed Handling Equipment  
Round Baler Belting • Milo Guards & Crop Savers

### President

**Mike Bergmeier** – Ext. 301  
Email: [mjbergmeier@shieldag.com](mailto:mjbergmeier@shieldag.com)

### Vice President

**Angie Bergmeier** – Ext. 311  
Email: [acbergmeier@shieldag.com](mailto:acbergmeier@shieldag.com)

### Sales Manager

**Andy Klamm** – Ext. 305  
Cell: 620-728-8630  
Email: [adklamm@shieldag.com](mailto:adklamm@shieldag.com)

### Office

General Manager/Engineer  
**Logan Hurlbut** – Ext. 315  
Email: [lhurlbut@shieldag.com](mailto:lhurlbut@shieldag.com)

#### Inside Sales

**Paul Ehler** – Ext. 303  
Cell: 620-728-8617  
Email: [prehler@shieldag.com](mailto:prehler@shieldag.com)

#### Accounting/Parts Department

**Iris Devena** – Ext. 308  
Email: [iddevena@shieldag.com](mailto:iddevena@shieldag.com)

#### Shipping

**Brenda Klug** – Ext. 304  
Email: [shipping@shieldag.com](mailto:shipping@shieldag.com)

# Warranty

Shield Agricultural Equipment (ShieldAg) and Acra-Plant warrant our products to be free of defects in materials and workmanship for a period of 180 days after the date of end user (consumer) purchase from the dealer. The warranty for whole goods equipment shall be exactly the warranty offered on these products by the original equipment manufacturer, and their individual warranties shall replace this warranty. This warranty does not apply to item(s), equipment or component parts that are found to have been subject to abuse or inadequate maintenance, that have been altered in any way or that have been used beyond their advertised capacity, rating or intended use. This warranty shall be for the repair or replacement of the defective item(s) at the sole discretion of Shield Agricultural Equipment. Any warranty replacement or repairs shall be subject to pro-rated consumer usage deductions as outlined below. Any warranty on tillage items expires after 1/2" of edge wear has occurred. Chrome products are warranted for defects in material and workmanship only, and the pro-rating system and 1/2" edge wear rule does not apply to chrome products. Chrome products are not guaranteed for use in rocky or frozen ground. This warranty does not extend to labor incurred in removal or replacement of any item(s). ShieldAg shall not be liable for incidental or consequential damages arising out of the use or inability to use the item(s) for any purpose whatsoever.

Execution of consumer rights for warranty repair or replacement:

1. Consumer must provide the dealer with evidence of date of purchase of the item(s) to be considered for warranty. This evidence shall be in the form of a copy of the invoice or bill of sale for the item(s) and this evidence shall accompany the item(s) alleged to be defective.
2. The dealer shall provide ShieldAg with #1, above, and with a copy of the ShieldAg invoice to the dealer for the same item(s).
3. The ShieldAg Territory Manager or the dealer shall complete a ShieldAg Returned Goods Authorization (RGA) for the item(s) alleged to be defective. It is the dealer's responsibility to return the item(s) to ShieldAg at the dealer's expense; however, the Territory Manager may elect to return the items(s) to ShieldAg via our truck. Extension of this courtesy does not constitute the final decision to authorize warranty replacement or repair for the item(s).
4. Upon receipt of the item(s) alleged to be defective and the RGA, the ShieldAg engineering department will inspect the item(s). The engineering department will have sole discretion to authorize warranty replacement or repair.
5. ShieldAg engineering department shall assign the pro-rated wear factors to all item(s) subject to a warranty claim. Since the range of item(s) varies widely, the assignment of pro-rated wear factor deductions shall be done in good faith, working with the ShieldAg Territory Manager, the dealer and the consumer. In general, warranty will be pro-rated for wear up to 1/2" of edge wear on the item(s). Any warranty on tillage items expires after 1/2" of edge wear has occurred. The pro-rating system and 1/2" edge wear rule does not apply to chrome products.
6. ShieldAg will at its sole discretion replace or repair the item(s) found to be defective, less the pro-rated wear factors. ShieldAg will return the item(s) that have been repaired or replaced to the dealer including free return transportation via the mode of our choice.

## Notes on Implied Warranties and Limitations

There is no implied warranty of merchantability or fitness for a particular purpose. Some states do not allow limitations on implied warranties of merchantability or fitness for a particular purpose, so this limitation may not apply in a given state. Some states do not allow the exclusion or limitation of incidental or consequential damages, so this limitation may not apply in a given state.

# Shipments & Returns

This "Shipments and Returns Policy" outlines the rights and obligations of Shield Agricultural Equipment (ShieldAg) and Acra-Plant dealers with regards to discrepancies in shipments and returns of unsold items to ShieldAg.

## Shipments

ShieldAg must be informed of any shortages in shipments within ten (10) days of the arrival of that shipment or shipments at the dealer or end user (in the case of drop-shipments from ShieldAg to the end user). Shortages for truck shipments via LTL, UPS or other common carrier should be forwarded to the carrier for adjustment via freight claim. Shortages deemed by ShieldAg corporate office or our Territory Managers to be our responsibility will be corrected through a credit on the account of the dealer or through replacement of the item(s) that were missing from the shipment. It is the sole responsibility of the dealer to count the item(s) received on shipments and to make appropriate claims for shortages within ten (10) days of the receipt of the item(s).

Execution of dealer rights for shipments:

1. Dealer shall provide ShieldAg with a copy of the ShieldAg packing slip (pick list) highlighting the item(s) that were alleged to be missing. A copy of the packing slip is to be faxed or mailed to ShieldAg within ten (10) days of the receipt of the shipment.
2. The ShieldAg Territory Manager may at our discretion be asked to visit the dealer and examine the shipment and shortage prior to extending credit or replacing the items.
3. ShieldAg will at its sole discretion replace the missing item(s) or credit the dealer account for the net dealer cost of the item(s) found to be missing. If replaced, ShieldAg will replace the missing item(s) to the dealer including free return transportation via the mode of our choice.

## Returns

ShieldAg will accept the return of new item(s) originally purchased into dealer stock from ShieldAg for a period of one (1) year from the date of original purchase from ShieldAg. Any acceptance of new item(s) older than one (1) year shall be subject to individual negotiation by the Territory Manager and corporate management of ShieldAg. ShieldAg reserves the right to refuse or accept returned merchandise. All items returned must be current to the stream of commerce in the geography where originally sold to the dealer and not deemed to be obsolete due to acts of nature or naturally occurring changes in consumer preference. All new items returned shall be in merchantable condition and shall not require repackaging, rework or repainting. Returned item(s) shall be subject to a twenty percent (20%) restocking charge. Returned item(s) shall not be accepted unless authorized in advance and in writing according to the "Execution of dealer rights for returned goods" outlined below.

Execution of dealer rights for returned goods:

1. Dealer shall provide ShieldAg with a copy of the original invoice for the item(s) to be returned and a written explanation of the reason for return.
2. The ShieldAg Territory Manager or the dealer shall complete a ShieldAg Returned Goods Authorization (RGA) for the item(s) to be returned. Upon inspection of the original invoice and the written explanation for return, the Territory Manager will authorize return of the item(s) for inspection and subsequent credit. It is the dealer's responsibility to return the item(s) to ShieldAg at the dealer's expense; however, the Territory Manager may elect to return the items(s) to ShieldAg via our truck. Extension of this courtesy does not constitute the final decision to extend return credit for the item(s).
3. Upon receipt of the item(s) and the RGA, ShieldAg will inspect the items for merchantability and general condition. Credit on account will only be applied after the items have been inspected and accepted. Credit against the dealer account receivable will be applied less the twenty percent (20%) restocking charge. There will be no cash refunds for returned items. The Territory Manager will communicate (to the dealer) acceptance (or rejection) of the returned goods and the final credit amount.

# ShieldAg Dealer Catalog

## Index

### Page

### Products

1	-----	Undercutter V-blades (sweep plow)
2	-----	V-blade identification chart
3--4	-----	Chisel and fallowmaster/fallow king sweeps
5--7	-----	Field cultivator sweeps and chisels, hardware
8	-----	Concave disc harrow blades
9	-----	Coulter blades for fertilizer and tillage machines
10--11	-----	Conservation Ripper Point CRP product listing for most disc rippers
12--13	-----	Chrome carbide Danish tyne and field cultivator sweeps
14--15	-----	Chrome carbide VPS and Orthman, Krause subsoiler and strip till points
16--17	-----	Chrome carbide subsoiler/ripper points for other makes
18	-----	Chrome carbide BluJet subsoiler points
19	-----	Chrome carbide shank/edge/digger repairs
21	-----	Planter and drill disc assemblies
22--23	-----	Hoe drill points and replacement hoe drill shoes
24--25	-----	Acra-Plant V-shot in-furrow
26	-----	Acra-Plant V-slice inserts
27	-----	Acra Drill Unit ADU repairs
28	-----	Fertilizer toolbar row units, berm builders and NH3 disc sealers
29	-----	Fertilizer shanks and shank mounts
30	-----	Acra-Plant fertilizer knives and chisel plow applicator knives and points
31	-----	Chisel Plow and Deep Furrow (MOLE) Knives
32	-----	Conventional and Side Dress Knives
33	-----	Front-swept and min-till / no-till knives
34	-----	Sweep tubes for applying fertilizer with chisels and sweeps
35	-----	Pry bars
36	-----	Plow bolts and bulk hardware
37--38	-----	U-bolts
39	-----	ARRO Corn Head Conversions
40--45	-----	Milo guards
46--47	-----	Crop savers
48--49	-----	Conveyors
50	-----	Baler belts
51	-----	Eze-Latch & Eze-Loc for Trailers
52	-----	Sugar Beet Lifter Wheels



# Shield V-Blades

## Get the Shield "Edge"

I WANT YOU



To Buy Products  
MADE IN THE USA

Shield Agricultural Equipment is located in the heart of wheat country. Shield V-blades are manufactured in Hutchinson, Kansas, and all development and testing work is done in Kansas, Colorado and Oklahoma. We are the only maker that continues to design, develop and manufacture V-blades in the territory where they are used. All of our territory managers are based in Hutchinson, Kansas and provide unsurpassed sales and service support.



Available in all standard widths, plain or hardfaced top or bottom, and with or without Chrome Carbide cap as shown here.

Feature	Benefit
Over 30 years experience manufacturing V-blades. Shield makes Plain, Top hardface, Bottom Hardface, Chrome Carbide Point (shown above) and Hardface Point V-Blades.	Developed and improved over time to provide long service life and value to farmer. Independent wear tests have proven the superiority of Shield V-blades in a wide variety of soil conditions.
Pricing is the same for all varieties of standard V-blades within a given width class, and Quinstar and Kent blades are priced separately	Easier to sell, no complicated pricing formulas or charts. Pricing is the same for top or bottom hardfacing, hardface or chrome carbide point.
Shield V-Blades meet or exceed original Equipment Manufacturer (OEM) specifications	Confidence in long service life. Shield V-blades will supply all of your needs for replacement blades, regardless of the brand of equipment.
Special carbon content and alloy mix in the V-blade steel	Longer wear life and resistance to impact damage
Bare Tube Stoodite material specially developed for Shield	More even application of hardface material yields more consistent wear and longer life, less horsepower per blade and lower fuel consumption
2" wide hardface band on standard V-blades, highest amount of applied hardfacing in the industry.	Assures long life and consistent wear, resistance to "saw-tooth" wear common to bottom hardfaced V-blades
Largest optional Chrome Carbide cap point in the business	Long wear life, blades wear evenly. Cap is preheated before installation, to assure proper weld integrity and perfect fit.
Over one pound of hardface material used for optional hardfaced point	Blends better with 2" band along blade edge for longer life and more even wear
Hollow ground blade edge	Excellent initial penetration and less horsepower per blade. Hollow grind process sets up even initial wear pattern which leads to consistent wear throughout the life of the blade.
V-blades manufactured on a standard frog in special welding jig	Assures proper fit for the farmer and more consistent wear in the field
Bolt holes countersunk deep on special fixture	Less bolt wear, less drag for lower fuel consumption

STRAIGHT FROM THE **HEARTLAND**



Learn more details at:

**SHIELDAG.COM**



Call for dealer nearest you  
**800-798-1968**

SHIPPING: 950 SCOTT BLVD • SOUTH HUTCHINSON, KS 67505 MAILING: PO BOX 687 • HUTCHINSON, KS 67504

**V-BLADES 75°**

B= Bottom hardface

CPB = Bottom hardface, chrome cap

Undercutter Sweep Plow

T= Top hard face

CPT = Top hardface, chrome cap

Blade Plow V-Blade

Part Number	Description	Weight
B5	5' bottom	57
CPB5	5' bottom chrome cap	57
CPT5	5' top chrome cap	57
T5	5' top	57
B5.5	5-1/2' bottom	61
CPB5.5	5-1/2' bottom chrome cap	61
CPT5.5	5-1/2' top chrome cap	61
T5.5	5-1/2' top	61
B6	6' bottom	63
CPB6	6' bottom chrome cap	63
CPT6	6' top chrome cap	63
T6	6' top	63
B6.5	6-1/2' bottom	69
CPB6.5	6-1/2' bottom chrome cap	69
CPT6.5	6-1/2' top chrome cap	69
T6.5	6-1/2' top	69
T7	7' top	78
KT4	4' Great Plains Kent, top hardfaced, 6-1/2" wide standard lift	53
KT4S	4' Great Plains Kent top hardfaced, low profile low lift	35
QB4	Quinstar and Roll-A-Cone Bottom	45
QT4	Quinstar and Roll-A-Cone Top	45

**PLAIN (non-hardfaced) and 100 degree Noble blades available with special order**  
**Plain Part numbers P5, P5.5 and P6 DO NOT HAVE HARDFACING**  
**100 Degree Noble blade part numbers ZT5, ZT5.5, ZT6, ZT6.5 & ZT7 require 8-12 week lead time**

Part Number	Blade mounting bolts, shin guards and replacement chrome caps	Weight
4-3	1/2 x 1-1/2 Bolt/nut box 50ea	6.5
4-3H	1/2 x 1-1/2 Bolt/nut box 50ea	7.5
4-3JH	1/2 x 1-1/2 Bolt/nut box 50ea	6.5
4-4	1/2 x 1-3/4 Bolt/nut box 50ea	7.0
4-4H	1/2 x 1-3/4 Bolt/nut box 50ea	7.8
4-4JH	1/2 x 1-3/4 Bolt/nut box 50ea	7.0
H3-4	7/16 x 1- 3/4 Bolt/nut box 50ea with 1/2" head	6.0
Z4-3	1/2 x 1-1/2 Bolt only per 500ea	43.0
Z4-4	1/2 x 1-3/4 Bolt only per 500ea	43.0
ZH3-4	Bolt only per 500ea 7/16" x 1 3/4" with 1/2"head	44.0
SMG-1	Stubble mulch shank guard, UHMW plastic, fitted	2.3
SNS-1	Chrome carbide cap	1.5



**ALL SHIELDAG V-BLADES  
Are made in Hutchinson, KS**

ShieldAg.com 800-798-1968

# SHIELDAG V-BLADE SPECIFICATIONS

SHIELDAG 75 DEGREE V-BLADES AVAILABLE WITH EITHER STOODITE POINT OR CAST CHROME CARBIDE POINT

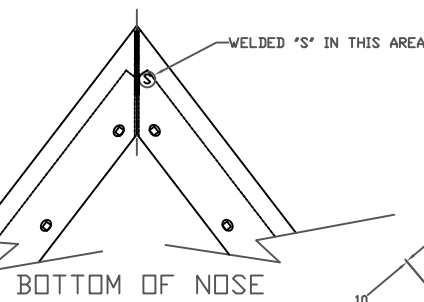
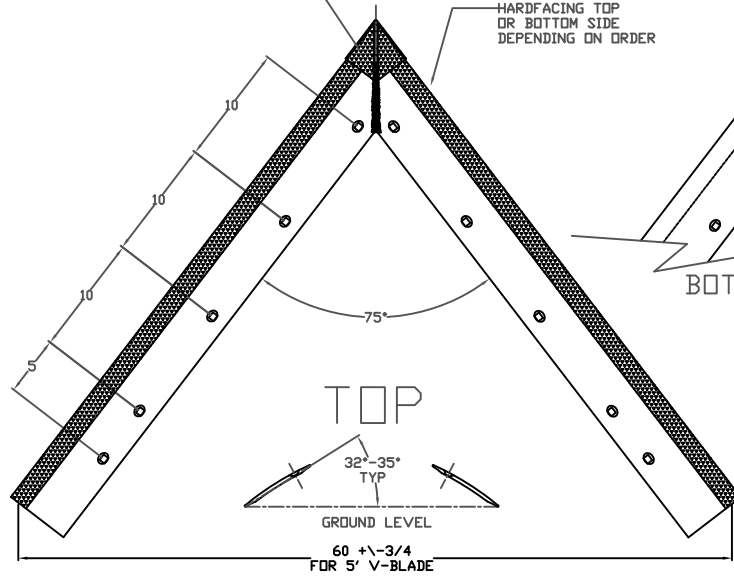

CAST POINT NOT AVAILABLE ON 100 DEGREE V-BLADES

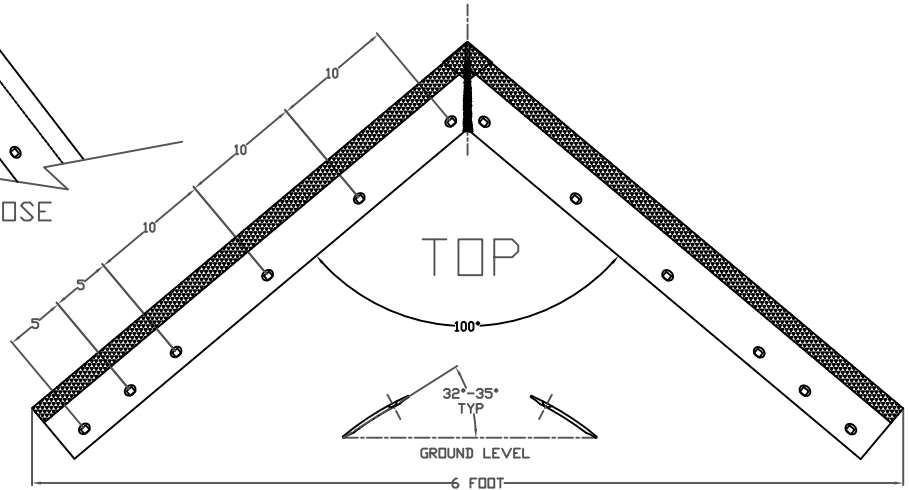

THEORETICAL WIDTH OF CUT (FEET)	NUMBER OF HOLES PER WING (SIDE)	SPACING BETWEEN HOLES
5 FOOT	5	3 EA 10' SPACING & 1 EA 5' SPACING
5-1/2 FOOT	6	3 EA 10' SPACING & 2 EA 5' SPACING
6 FOOT	7	4 EA 10' SPACING & 2 EA 5' SPACING
6-1/2 FOOT	8	4 EA 10' SPACING & 3 EA 5' SPACING
7 FOOT	8	4 EA 10' SPACING & 3 EA 5' SPACING
7-1/2 FOOT	9	5 EA 10' SPACING & 3 EA 5' SPACING
8 FOOT-OBSOLETE	9	5 EA 10' SPACING & 3 EA 5' SPACING
9 FOOT-OBSOLETE	11	5 EA 10' SPACING & 5 EA 5' SPACING

THEORETICAL WIDTH OF CUT (FEET)	NUMBER OF HOLES PER WING (SIDE)	SPACING BETWEEN HOLES
5 FOOT	5	2 EA 10' SPACING & 2 EA 5' SPACING
5-1/2 FOOT	5	2 EA 10' SPACING & 3 EA 5' SPACING
6 FOOT	6	3 EA 10' SPACING & 2 EA 5' SPACING
6-1/2 FOOT	7	3 EA 10' SPACING & 3 EA 5' SPACING
7 FOOT	8	3 EA 10' SPACING & 4 EA 5' SPACING
7-1/2 FOOT	8	3 EA 10' SPACING & 4 EA 5' SPACING
8 FOOT-OBSOLETE	8	3 EA 10' SPACING & 4 EA 5' SPACING
9 FOOT-OBSOLETE	9	4 EA 10' SPACING & 4 EA 5' SPACING

NOTE: QUINSTAR LASER PLOW USES SPECIAL 4' BLADE WITH 5 HOLES SPACED AT 7 1/2' KENT PLAINS PLOW USES SPECIAL 4' BLADE WITH 4 HOLES SPACED AT 10' V-BLADES FOR KENT & SUNFLOWER ARE ALSO AVAILABLE WITH SINGLE EDGE MATERIAL STANDARD 4 FOOT BLADES ARE ALSO MADE BY SHIELDAG EQUIPMENT BUT ARE GENERALLY NOT A STOCK ITEM. PLEASE CALL FOR AVAILABILITY.

NOTE: VIRTUALLY ALL V-BLADES ARE PUNCHED AND WELDED TO FIT NOBLE V-BLADE SPECIFICATIONS. THERE ARE EXCEPTIONS SUCH AS THE QUINSTAR LASER, KENT PLAINS PLOW, THE MARTEN-RATSLAFF (BUILT IN OK) AND SOME OF THE EARLY YEAR JOHN DEERE. WE CURRENTLY STOCK ONLY THE QUINSTAR LASER AND THE KENT PLAINS PLOW BLADES.



800-798-1968  
WWW.SHIELDAG.COM

SUNFLOWER MFG. PRODUCES SOME UNITS USING BLADES WITH 1/4 FOOT INCREMENTS (I.E. 5 1/4, 6 1/4) THESE ARE MANUFACTURED RIGHT HAND AND LEFT HAND VERSIONS. THEY ARE PRODUCED ONLY PER ORDER, WHICH REQUIRES ABOUT 3 WEEKS LEAD TIME. BOLT SPACING WILL GENERALLY HAVE ONE MORE HOLE ON THE LONG SIDE.



# 27" Fallow-Sweep

**ShieldAg has changed our fallow-sweep width to 27-1/2", to assure a 27" cut width in all conditions.**

Our fallow-sweeps come with Surfa-Shield™ wear protection on cutting edges and the stem, extending total wear life. They go through a shot peening process before and after the Surfa-Shield™ is applied to relieve stress and improve overall durability. Made from 5/16" Boron steel with a drop nose, our sweeps "take the ground" easily in rough conditions. For smooth weed-free fields, choose ShieldAg 27" sweeps!



PCS-DFT27

ShieldAg 27" sweeps are available with  
TOP Surfa-Shield (PCS-DFT27) or  
BOTTOM Surfa-Shield (PCS-DFB27)

**ShieldAg continues to be the only manufacturer of 27" sweeps using:**

- 5/16" Boron-Steel and Surfa-Shield™ ultra-smooth wear protection
- Surfa-Shield™ wear protection on edges, nose AND stem for maximum wear life
- "Drop-nose" forge tooling to make sure the sweep will "take the ground" in tough conditions
- Shot-peening process before AND after coating with Surfa-Shield™



[www.shieldag.com](http://www.shieldag.com) | (800) 798-1968

## ***Chisel Plow Sweeps--50 degree stem angle***

Part #	SIZE	WEIGHT
CPS4-16	1/4" X 16", plain	7.6
CPS5-SST18	5/16 X 18" with Surfa-Shield	9.5
CPS4-18	1/4" X 18", plain	8.5

## **5/16" Heavy-Duty 8" wide Penetrator**

Part #	SIZE	WEIGHT
PS5-08	5/16 X 8" plain	4.6
PS5-SST08	5/16 X 8" with Surfa-Shield	4.9
PS5-HFT08	5/16 X 8" with top hardface	5.1

## ***Conservation Sweeps ("fallowmaster/king")***

Part #	SIZE	WEIGHT
PCS-DFB27	5/16 X 27 1/2" sweep Surfa-Shield Bottom and Stem	15.8
PCS-DFT27	5/16 X 27 1/2" sweep Surfa-Shield TOP and Stem	15.8



PS5-HFT08



PCS-DFT27

## **Grade 5 Plow Bolt/Nut for Chisel Plow and Conservation Sweeps**

Part#	SIZE	WEIGHT
4-7	1/2 x 2-1/2 Bolt/nut box 50ea	9
Z4-7	1/2 x 2-1/2 Bolt only per 500ea	68

## **Plastic Shank Cushions**

Part #	DESCRIPTION	WEIGHT
CPG-1	2 x 10" chisel plow guard	0.25
CPG-2	Cushion blocks for 26" sweeps	0.17
FCG-1	1-5/8 x 9" field cultivator guard	0.15



# ShieldAg 1/4" Field Cultivator Sweeps With Surfa-Shield™ Wear Protection

Our 27" sweeps ("fallow-king", "fallow-master") have been an industry-leader for over 15-years!

We also offer the same world-class performance with our field cultivator sweeps. 1/4" FCC4-SST-series clipped wing (true width) 2-bolt sweeps are available with Surfa-Shield™ on the cutting edge and stem!

*Surfa-Shield™ 1/4" wear-coated sweeps*

<b>Part #</b>	<b>Width</b>	
<b>FCC4-SST08</b>	<b>8"</b>	
<b>FCC4-SST09</b>	<b>9"</b>	<b>Field cultivator sweeps use (2) 7/16" plow bolts on 1-3/4" centers</b>
<b>FCC4-SST10</b>	<b>10"</b>	
<b>FCC4-SST11</b>	<b>11"</b>	
<b>FCC4-SST12</b>	<b>12"</b>	

*Ask your Territory Manager for a cross-over OEM part number index*

Continuous product improvement yields these benefits:

- Point and edges forged full-length to self-sharpen
- Out wear plain or hard-faced sweeps
- Drop-nose to take the ground in the toughest conditions

# C34-SP Chisel Spike

Our popular C34-SP Heavy-Duty Chisel Spike reduces “sledding” on disc chisels and standard chisels with shank angles less than 50°

**Tallest Chrome Carbide Heel  
In The Industry  
To Protect Bolt Holes**

***Works Great On  
Disc Chisels!***



**Designed For 42° - 50°  
Chisel Shank**

- Designed to flow soil ABOVE the bolts so they do not wear out before the Chrome Carbide Point
- Self-sharpens as it wears, using a massive Chrome Carbide Point
- Has excellent initial penetration in a wide variety of soil conditions



2-bolt Field Cultivator Sweeps - 47° Stem Angle

Part #	SIZE	WEIGHT
FCC4-SST08	8" X 1/4", Surfa-Shield, two-hole	3
FCC4-SST09	9" X 1/4", Surfa-Shield, two-hole	3.1
FCC4-SST10	10" X 1/4", Surfa-Shield, two-hole	3.2
FCC4-SST11	11" X 1/4", Surfa-Shield, two-hole	3.5
FCC4-SST12	12" X 1/4", Surfa-Shield, two-hole	3.7

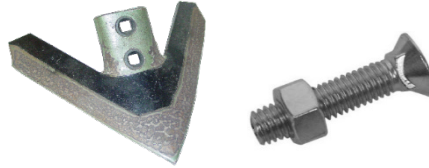

FCC4-SST10

**ASK ABOUT OUR  
TA-1, TA-2 AND TA-3  
FERTILIZER TUBES  
FOR USE WITH  
SWEEPS AND CHISELS**

Standard bolt boxes for Field Cultivator sweeps

Part #	SIZE	WEIGHT
3-4	7/16 x 1-3/4 Bolt/nut box 50ea	6
Z3-4	7/16 x 1-3/4 Bolt only per 500ea	44

Part #	Chisels & Spikes	WEIGHT
C34	13 x 3/4 x 2", Chrome Cap	5.6
C34-SP	13 x 3/4 x 2", HEAVY-DUTY Chrome Cap	7.2
123HL	22 x 1/2 x 3", twisted LEFT	8.4
123HR	22 x 1/2 x 3", twisted RIGHT	8.4
123HL/HF	22 x 1/2 x 3" hardfaced, twisted LEFT	8.6
123HR/HF	22 x 1/2 x 3" hardfaced, twisted RIGHT	8.6
1858	18 x 5/8 x 2", double end forged chisel	5.6
1858/HF	18 x 5/8 x 2", hardfaced	5.8
1878	18 x 7/8 x 2", double end forged chisel	7.4
1878/HF	18 x 7/8 x 2", hardfaced	7.6
KB-1	Crustbuster double end point	1.5



1858



C34



C34-SP

Recommended Grade 5 Plow Bolt/Nut for CHISELS

Part#	SIZE	WEIGHT
4-7	1/2 x 2-1/2 Bolt/nut box 50ea	9
Z4-7	1/2 x 2-1/2 Bolt only per 500ea	68

Mounting Wedge to adjust angle, fits all chisels and spikes

Part #	DESCRIPTION	WEIGHT
AP-708003	5° Mounting cast wedge	0.4

Plain Concave Disc Blades

Part #	Size	Concavity	Center hole	Weight
20 DB7-3	20" X 7ga 4.5mm	2"	1-1/8 SQx1-1/4 SQ	16.3
20 DB7-5	20" X 7ga 4.5mm	2"	1-1/2" Round	16.3
20 DB7-PH	20" X 7ga 4.5mm	2"	3/4" Pilot hole	16.3
22 DB7-3	22" X 7ga 4.5mm	2.5"	1-1/8 SQx1-1/4 SQ	20
22 DB7-5	22" X 7ga 4.5mm	2.5"	1-1/2" Round	20
22 DB7-7	22" X 7ga 4.5mm	2.5"	1-3/4" Round	20
22 DB7-PH	22" X 7ga 4.5mm	2.5"	3/4" Pilot hole	20
24 DB6-4	24" X 6ga 5mm	3"	1-1/4 SQ x 1-1/2RD	26.5
24 DB6-5	24" X 6ga 5mm	3"	1-1/2" Round	26.5
24 DB6-7	24" X 6ga 5mm	3"	1-3/4" Round	26.5
24 DB6-PH	24" X 6ga 5mm	3"	3/4" Pilot hole	26.5

Disc blades are Boron Steel heat treated and tempered, sharpened on one side  
 -PH pilot holes may be used to make special center holes, cut charges MAY apply



**BOLD HIGHLIGHTED COLUMNS ARE MOST IMPORTANT FOR IDENTIFYING BLADES**

SHIELD BLADES 17"---27" IDENTIFICATION CHART

Part Number	Diameter	STYLE	Center hole	THICK MM	THICK Inches	Bolt Circle	# of Bolt holes	Bolt hole diameter	Weight lbs	TYPICAL USE
<b>17FLYET CLT</b>	<b>17"</b>	<b>Crucible Fluted</b>	<b>4"</b>	4.5	0.177	<b>5.25"</b>	<b>4</b>	0.53	11.88	Fertilizer
17WB COMBO	17"	12-wave 3/4" overall wave height	3-11/16"	4.5	0.177	5.0" & 5.25"	8	0.53	11.88	Sealer
17WB CLOSER	17"	12-wave 3/4" overall wave height	1-25/32"	4.5	0.177	5.0"	4	.53 SQ	11.88	Sealer
18 DB11-NO	18"	18" Dalton Notched Sealer	2-1/4"	3.5	0.138	4.0"	4	0.44	8.80	Sealer
18DD6-3	18"	Smooth, Deere 1800-series Air seeder	3.03	5.0	0.197	4.4"	4	10mm	13.00	Air Seeder
20FL CLT	20"	Fluted	3-11/16"	4.5	0.177	5"	4	0.53	16.28	Tillage
20FL ORTH	20"	Fluted	2-49/64"	4.5	0.177	4.3	4	0.41	16.28	Tillage
20FL COMBO	20"	Fluted	3-11/16"	4.5	0.177	5.0" & 5.25"	8	0.53	16.28	Fertilizer
20NO COMBO	20"	Notched	3-11/16"	4.5	0.177	5.0" & 5.25"	8	0.53	16.28	Fertilizer
20FLYET CLT	20"	Crucible Fluted	4"	4.5	0.177	5.25	4	0.53	16.28	Tillage
20FLC COMBO	20"	Crucible Fluted	3-11/16"	4.5	0.177	5.0" & 5.25"	8	0.53	16.28	Fertilizer
20PL COMBO	20"	Smooth	3-11/16"	4.5	0.177	5.0" & 5.25"	8	0.53	16.28	Fertilizer
20PL CLT	20"	Smooth	3-11/16"	4.5	0.177	5	4	0.53	16.28	Tillage
20WB8 COMBO	20"	8-WAVE 1-3/4" overall wave height	3-11/16"	4.5	0.177	5.0" & 5.25"	8	0.53	16.28	Fertilizer
20WB12 COMBO	20"	12-WAVE 3/4" overall wave height	3-11/16"	4.5	0.177	5.0" & 5.25"	8	0.53	16.28	Fertilizer
20WB20-COMBO	20"	20-Wave Spriral wave	3-11/16"	4.5	0.177	5.0" & 5.25"	8	0.53	16.28	Fertilizer
20VT-COMBO	20"	25-wave, Z-wave, 1/2" overall height	3-11/16"	5.0	0.197	5.0" & 5.25"	8	0.53	18.10	Fertilizer
20DD6-3	20.4"	Smooth, JD Cultivator Blade, N216270	3-1/32"	4.5	0.177	4.4"	4	0.40	17.00	Tillage
22FL CLT	22"	Fluted	4"	4.5	0.177	5.5	5	0.53	19.80	Tillage
22PL CLT	22"	Smooth	4"	4.5	0.177	5.5	5	0.53	19.80	Tillage
24PL CLT	24"	Smooth	4"	4.5	0.177	5.5	5	0.53	26.18	Tillage
24PL COMBO	24"	Smooth	3-11/16"	5.0	0.197	5.0" & 5.25"	8	0.53	26.18	Fertilizer
24PLDBJ CLT	24"	Smooth	3-11/16"	5.0	0.197	5.0"	4	0.53	26.18	Fertilizer
25PL-CLT6	25"	Smooth, Krause Gladiator	3-11/16"	6.0	0.236	5"	4	0.53	31.00	Strip Till
27PL6 CLT	27"	Smooth Orthman	4-1/16"	6.0	0.236	5.5	5	0.53	33.13	Orthman
KSC-33551445N	14"	14" DMI Notched Sealer	2-17/32"	3.5	0.138	4.0"	4	.53 SQ	7.04	Sealer
KSC-33551445	14"	14" DMI Plain Sealer	2-17/32"	3.5	0.138	4.0"	4	.53 SQ	7.04	Sealer
KSC-33551870	18"	18" DMI Plain Sealer, Dull	1-25/32"	3.5	0.138	5.0"	4	.53 SQ	8.80	Sealer



20FL-COMBO  
20" Dia  
Flutes to the edge  
8 bolt holes  
3-7/16" center hole



20FLC-COMBO  
20" Dia  
Flutes with smooth edge  
8 bolt holes  
3-7/16" center hole



20PL-COMBO  
20" Dia  
SMOOTH (Plain)  
8 bolt holes  
3-7/16" center hole



17WB-COMBO  
17" Dia  
12-wave, 3/4" height  
8 bolt holes  
3-7/16" center hole



20NO-COMBO  
20" Dia  
Notched RIM  
8 bolt holes  
3-7/16" center hole



20VT-COMBO  
20" Dia  
Z-shaped flutes  
25 flutes, 1/2" overall  
8 bolt holes  
3-7/16" center hole

# Acra Plant Conservation Ripper Points

Available in 7" & 10" winged points and Narrow Points with No Wing

Does your Conservation Tillage Yield Improvement Program include Subsoiling or Disc/Ripping to relieve compaction zones and improve soil tilth?

**Our CRP Points  
are designed to:**



- Relieve soil compaction zones for **YIELD IMPROVEMENT**
- Improve **SOIL TILTH** to increase nutrient availability and root uptake
- Produce a subsoil profile that assures improved root penetration
- Assure moisture retention in the driest conditions
- Provide fracture and lift with little surface disruption or "slabbing"
- Allow flexibility in running depth
- Scour up, pull easy and flow soil around the shank to reduce wear
- Provide long wear life in the widest variety of soil conditions



Our unique design allows us to use solid 25% chrome carbide in all of the wear surfaces with mounting boots are designed to fit most makes and models of disc rippers and subsoilers.

**Start your Conservation Tillage Yield  
Improvement program today!**



[www.shieldag.com](http://www.shieldag.com) | (800) 798-1968



Part #	Description and OEM Machine Fit	Shank Width	Weight lbs	Machine Reference	2023 RETAIL
CRP-1	7" Winged, Deere 510 512 2700, Baker, Krause TL3000 & 4880, Laney	1-1/4	15.8	Deere	\$228.00
CRP-1-10	10" Winged, Deere 510 512 2700, Baker, Krause TL3000 & 4880, Laney	1-1/4	16.6	Deere	\$234.00
CRP-2	7" Winged, DMI, CaseIH 870 9300 530 730, Krause Dominator	1-1/4	15.8	CNH/DMI/KRAUSE	\$240.00
CRP-2-10	10" Winged, DMI, CaseIH 870 9300 530 730, Krause Dominator	1-1/4	16.6	CNH/DMI/KRAUSE	\$246.00
CRP-2B	7" Winged, Brillion Land Commander 1 & 2	1-1/4	15.8	Brillion	\$250.00
CRP-2B-10	10" Winged, Brillion Land Commander 1 & 2	1-1/4	16.8	Brillion	\$256.00
CRP-3	7" Winged, DMI, CaseIH 870 9300 530 730	1-1/2	15.8	DMI/CNH	\$228.00
CRP-3-10	10" Winged, DMI, CaseIH 870 9300 530 730	1-1/2	16.6	DMI/CNH	\$234.00
CRP-4	7" Winged, Sunflower 4200, 4400, 4500 & M&W Earthmaster*** SEE NOTE	1-1/4	15.8	Sunflower/M&W	\$228.00
CRP-4-10	10" Winged, Sunflower 4200, 4400, 4500 & M&W Earthmaster *** SEE NOTE	1-1/4	16.6	Sunflower/M&W	\$234.00
CRP-6	2-1/2" Narrow Point (no wings), DMI, CaseIH 870 9300 530 730, Krause Dominator	1-1/4	13.8	CNH/DMI/KRAUSE	\$232.00
CRP-7	2-3/8" Flat top, JD 510 512 2700, Baker, Krause TL3000 & 4880, Laney	1-1/4	12	Deere	\$165.00
CRP-8	2-1/2" Narrow Point, Deere 510 512 2700, Baker, Krause TL3000 & 4880, Laney	1-1/4	13.8	Deere	\$220.00
CRP-9	7" Winged, Brent Earthquake & CPC	1-1/4	15.8	Brent	\$248.00
CRP-9-10	10" Winged, Brent Earthquake & CPC	1-1/4	16.6	Brent	\$254.00
CRP-9R	2-1/2" Narrow Point (no wings), Unverferth / Rawson Zonebuilder	3/4	13.8	Rawson/Unverferth	\$233.00
CRP-9RW	7" Winged, Unverferth / Rawson Zonebuilder	3/4	15.8	Rawson/Unverferth	\$241.00
CRP-10	2-1/2" Narrow Point (no wings), Landoll Weatherproofer 2200-2300- series	1-1/8	13.8	Landoll 2200-	\$233.00
CRP-11	7" Winged, Landoll Weatherproofer 2200-2300-series	1-1/8	15.8	Landoll 2200-	\$241.00
CRP-11-10	10" Winged, Landoll Weatherproofer 2200-2300-series	1-1/8	16.8	Landoll 2200-	\$246.00
CRP-12	7" Winged, Caldwell/Graber	1-1/2	15.8	Caldwell	\$244.00
CRP-13	2-1/2" Narrow Point (no wings), Brillion subsoilers with 1" shank	1	14	Brillion	\$243.00
CRP-14	7" Winged, Brillion subsoilers with 1" shank	1	15.8	Brillion	\$248.00
CRP-14-10	10" Winged, Brillion subsoilers with 1" shank	1	16.8	Brillion	\$254.00
CRP-15	7" Winged, Koenig DWK-series	1-1/2	15.8	Koenig	\$242.00
CRP-15N	2-1/2" Narrow point (no wings), Koenig DWK-series	1-1/2	14.5	Koenig	\$236.00
CRP-16	7" Winged, Laney Extra Heavy Duty Plow	1-1/2	15.8	Laney	\$248.00
CRP-17	2-1/2" Narrow Point (no wings), DMI, CaseIH 870 9300 530 730	1-1/2	13.8	DMI/CNH	\$236.00
CRP-18	2-1/2" Narrow Point (no wings), Unverferth 310/330/332 Ripper/Stripper	3/4	13.8	Unverferth	\$226.00
CRP-19	7" Winged, Worksaver V-ripper	1-1/4	15.8	Worksaver	\$244.00
CRP-20	2-1/2" Narrow Point (no wings), Brillion ST-30 Rip/Strip narrow shank	3/4	13.8	Brillion	\$234.00
CRP-21	2-1/2" Narrow Point (no wings), Allis #9	1	16.8	Allis	\$243.00
CRP-24	2-1/2" Narrow Point, Sunflower 4200, 4400, 4500 & M&W Earthmaster *** SEE NOTE	1-1/4	16.8	Sunflower/M&W	\$220.00
CRP-25	7" Winged, Unverferth Ripper/Stripper	3/4	16.8	Unverferth	\$234.00
CRP-26	2-1/2" Narrow Wilrich SoilPro & 657 DCR/ripper, Sunflower 4600 & 4700 series *** SEE NO	1-1/4	13.8	Wilrich/Sunflower	\$232.00
CRP-26-7	7" Winged, Wilrich SoilPro & 657 DCR/ripper, Sunflower 4600 & 4700 series *** SEE NOTE	1-1/4	16	Wilrich/Sunflower	\$238.00
CRP-26-10	10" Winged, Wilrich SoilPro & 657 DCR/ripper, Sunflower 4600 & 4700 series *** SEE NOT	1-1/4	16.9	Wilrich/Sunflower	\$246.00
CRP-28	7" Winged, Dammer-Diker and Tillage Master, CRP-1 & -8 also fit some models	1-1/4	15.8	Dammer	\$241.00
CRP-34	7" Winged, Besler 4000-series	1-1/4	15.6	Besler	\$239.00
CRP-37	7" Winged, Quinstar/Orthman SoilShark	1-1/4	15.8	Orthman	\$238.00
CRP-44	2-1/2" Narrow Point, Great Plains Verti-Till 4360/6360 & Turbo-Chisel TC 5-series	1-1/4	13.8	Great Plains	\$238.00
CRP-44-7	7" Winged, Great Plains Verti-Till 4360/6360 & Turbo-Chisel TC-5 series	1-1/4	16	Great Plains	\$246.00
CRP-44-10	10" Winged, Great Plains Verti-Till 4360/6360 & Turbo-Chisel TC-5 series	1-1/4	16.9	Great Plains	\$252.00
CRP-50	2-1/2" Narrow CRP, Landoll WP 2410/2430-series	1-1/4	14	Landoll 2400-	\$235.00
CRP-50-7	7" Winged CRP, Landoll WP 2410/2430-series	1-1/4	16	Landoll 2400-	\$239.00
CRP-50-10	10" Winged CRP, Landoll WP 2410/2430-series	1-1/4	16.5	Landoll 2400-	\$246.00
CRP-50LS	Shin guard Landoll WP 2410/2430-series	1-1/4	4.5	Landoll 2400-	\$145.00
CRP-60	2-1/2" Narrow Point (no wings) Unverferth 112, 122 and 132 zone builders	3/4	16	Unverferth	\$248.00
CRP-60-7	7" Winged, Unverferth 112, 122 and 132 zone builders	3/4	19	Unverferth	\$270.00
CRP-77	7" Winged, BluJet Subtilers, all	1-1/4	21	Blu Jet	\$272.00
CRP-710	10" Winged, BluJet Subtilers, all	1-1/4	22	BluJet	\$278.00

\*\*\*NOTE Sunflower 4213, 4233, 4412, 4511 and 4530 disk rippers continue to use the CRP-4, CRP-4-10 and CRP-24 points  
 \*\*\* NOTE Wilrich MAKES the Sunflower disc rippers 4610, 4630, 4710 and 4730, those models use CRP-26-series points

Deere 2700-series includes 2720 Disk Rippers and 2730 combo rippers: Landoll's new 2410 and 2430-series WeatherProofers take a two piece point and shin guard  
 Unverferth's new 112, 122 and 132 Zone builders are different than the older Unverferth / Rawson Rip/Strippers (CRP-18) and Zone Builders (CRP-9R and -9RW)



All ShieldAg CRP-series Disc Ripper/Subsoiler points are 100% Made in USA with solid chrome carbide top castings !!  
 ShieldAg.com 800-798-1968



# FULL LINE OF CHROME CARBIDE SWEEPS FROM SHIELDAG

We have re-tooled ALL of our Acra-Plant chrome sweep line to improve quality and reduce prices across the board!

- Improved fit and finish
- Updated Acra-exclusive chrome carbide to extend wear life
- Hardware supplied with all models

AP-860102



1"

AP-860202



2-3/4"

### DANISH 860-SERIES POINTS & SWEEPS

Hardware and rubber fitment shim supplied with all 860-series

AP-860402



4"

AP-860702



7"

AP-861202



2-3/4"

### KONGSKILDE 861-SERIES CONSERTINE SWEEPS

Correct 7/16" hardware supplied with all 861-series

AP-861402



4"

AP-871102



2-3/4"

AP-871104



4"

### ACRA 871-SERIES FIELD CULTIVATOR POINTS & SWEEPS

All 871-series hole & slot field cultivator sweeps are supplied with 7/16" bolts --rubber shim is furnished with 4", 7" and 9" sweeps optional hardware packs and fitment shims available to optimize fitup for a wide variety of field cultivators

\* Special 3/8" hardware available for cultivator shanks with 3/8" mounting holes

AP-871107



7"

AP-871109



9"



## [800] 798-1968

[www.shieldag.com](http://www.shieldag.com) [www.acraplant.com](http://www.acraplant.com)

PO Box 687 • Hutchinson, KS 67504-0687 • Fax (620) 662-7482

**ORIGINAL ACRA-TUFF DANISH TYNES AND FIELD CULTIVATOR SWEEPS**  
 Acra-Tuff Alloy Danish Tynes and Field Cultivator points/sweeps will OUT LAST stamped steel parts by 3 to 5 TIMES !!!



Danish 1-HOLE sweeps for round-tyne Danish cultivators

Part Number	Description, single-hole Danish	WEIGHT, lbs	RETAIL
AP-860102	1" Spike w/hdwre and shim, single hole mounting	0.9	\$9.99
AP-860202	2-3/4" Goosefoot w/hdwre and shim, single hole mounting	1.2	\$10.99
AP-860402	4" Sweep w/hdwre and shim (4" OK Sweep), single hole mounting	1.2	\$11.99
AP-860702	7" Sweep w/hdwre and shim (7" OK Sweep), single hole mounting	2.2	\$18.49

All 860-series single-hole Danish Chrome Carbide sweeps are furnished with the proper hardware kit and the rubber cushioning shim

**Kongskilde (CNH-New Holland Tillage) 2-hole Danish for Consertine shanks, VTH, VTL and VTM-style**

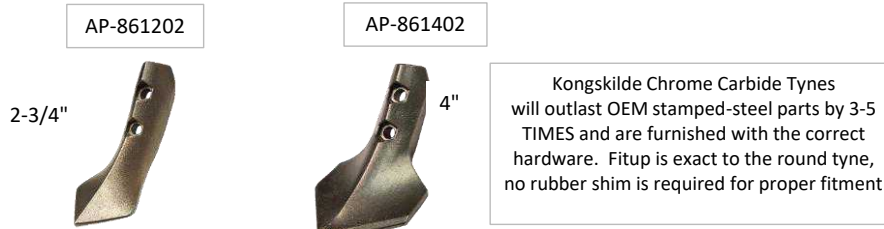

Part Number	Description, Kongskilde 2-hole Danish tyne	WEIGHT, lbs	RETAIL
AP-861202	Kongskilde 2-3/4" 2-hole, with hardware, no shims, KG# 101002002	1.8	\$15.99
AP-861402	Kongskilde 4" duckfoot 2-hole, with hardware, no shims, KG# 101002003 and 101002004	3	\$27.49

All 861-series Kongskilde points are furnished with the proper 2-bolt set

**Chrome Carbide Field Cultivator Points and Sweeps**

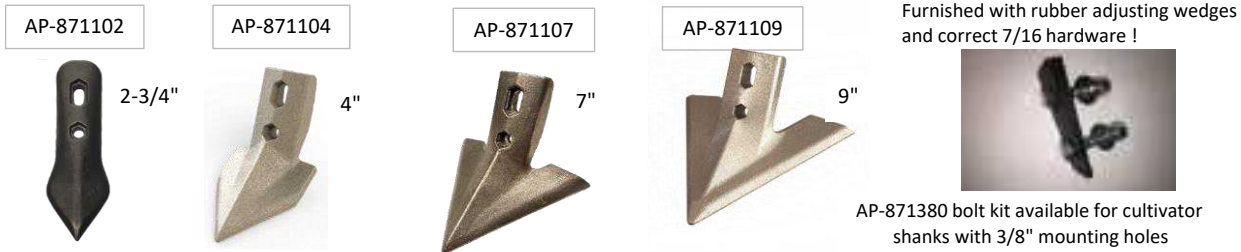

Part Number	Hole/slot field cultivator points and sweeps	WEIGHT, lbs	RETAIL
AP-871102	Field cultivator point, 2-3/4", hole/slot, with hardware, no shims	2.4	\$16.99

AP-871102 replaces ACRA AP-871101 and AP-871201, Extra flat washer included in AP-871102 to "pitch" the cultivator point as needed

Part Number	Description	WEIGHT, lbs	RETAIL
AP-871104	Field cultivator hole/slot, 4" duckfoot, with hardware	3.5	\$29.99
AP-871107	Field cultivator hole/slot, 7" sweep, with hardware	4.8	\$34.99
AP-871109	Field cultivator hole/slot, 9" sweep, with hardware	5.5	\$39.49
AP-871380	<b>Special bolt kit for field cultivators with 3/8" diameter shank holes, generally Deere models</b>	0.4	\$7.99
AP-501226	Radius fitment shim to allow for special OEM cultivator shanks with flattened soil ends	0.2	\$3.49

All 871-series chrome carbide field cultivator points & sweeps furnished with the proper 7/16" hardware kit & rubber 5-degree wedge

# AP-800106

## Acra Replacement Point

- More lift and fracture of the soil profile for optimum strip till results
- Reduced wear on the OEM shank
- “Diamond” nose is directly from our terrific design for our standard ST-Series knives, designed to increase wear life
- Design of the mole foot (and fin) will reduce sidewall compaction and nearly eliminate “gully washers” right down the strip-tilled row in case of heavy rains within a week or two of the strip till pass
- Casting materials is ACRA-EXCLUSIVE and proprietary; a great combination of improved wear life and toughness
- Absolutely World-Class foundry capability and quality control. The best of the best!
- The AP-800106 now available from ShieldAg, replaces Orthman P/N 164-054 & 164-057

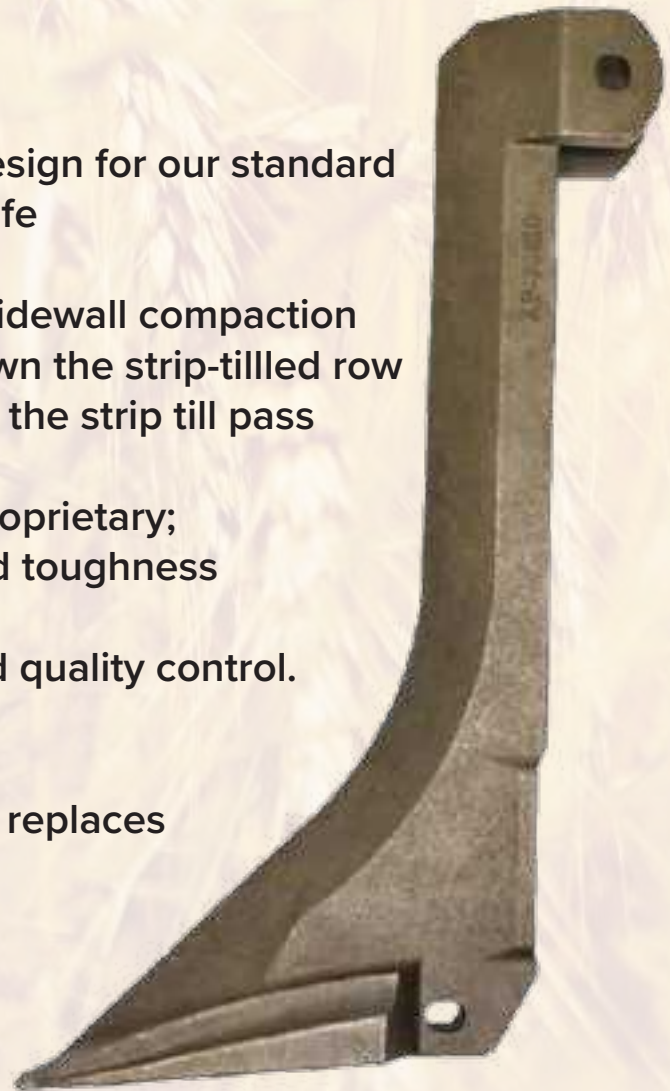

Acra Plant Chrome Carbide V-Crown Ripper Points and Shank Guards

Item	DESCRIPTION AND MACHINE FIT	WEIGHT
AP-10420	Replacement Shank for for Acra VPS 2000	132
AP-20406	Replacement Shank for Acra VPS 3000	88
TF-820101	RIPPER POINT, VPS 2000 without WINGS, casting # TF820101	4.8
TF-820102	RIPPER POINT, VPS 2000 with WINGS, casting # TF820102	5.6
TF-820108	RIPPER POINT, VPS 3000 with WINGS, casting # TF820108	10.21
TF-129	SHANK GUARD for ACRA VPS & QUINSTAR RIPPERS TF820116	10.1
RP-112	1/2" X 1-1/2" Spring pin for all Acra VPS points	0.05



**TF-820102**  
(VPS 2000)



**TF-820108**  
(VPS 3000)



**TF-129**  
(VPS &  
QUINSTAR)

Item	DESCRIPTION AND MACHINE FIT, ORTHMAN AND KRAUSE SUBSOILERS	WEIGHT
AG-8001-DF	RIPPER POINT Orthman Dorsal Fin, casting # AG-8001-DF	4.75
AP-800102	RIPPER POINT w/PIN Orthman 2" CP20, casting # TF800102	3.42
AP-800104	RIPPER POINT w/PIN Orthman 4", casting # TF800104	4.7
AP-800106	Orthman Strip Till Point	12
TF-102	Krause standard Cultivator point , loop ears	2.1
TF-103	Spring Cultivator Point Krause/Hamby/Johnson, casting #103	2.68
TF-104	Shank Guard Krause 4650	6.5
TF-122	Tillage Point Krause/Hamby/Johnson, Fall Point, casting #122	3



**AG-8001-DF**  
(ORTHMAN)



**AP-800102**  
(2" ORTHMAN)



**AP-800104**  
(4" ORTHMAN)

IMPROVED ORTHMAN  
STRIP TILL POINT!



**TF-103**



**TF-122**



**TF-104**  
(KRAUSE)



**AP-800106**  
(ORTHMAN)

ALL CHROME CARBIDE CASTINGS ARE MADE FROM THE ORIGINAL ACRA-TUFF ALLOY  
ShieldAg.com 800-798-1968



# New and Improved AP-800601

KWRP1, JRP1, AP-800601, 8006-01, BRP1  
Subsoilers with 1-1/4" shank

**Redesigned and updated casting  
for overall improved performance  
in today's field applications**

*S3 is "Shield Soil Splitter" technology. It is a casting design feature that provides tremendous value, by splitting the soil at the top of our castings to minimize wear on shanks and reduce "slabbing" at the surface.*

Redesigned shank to casting mounting pocket for consistent fit

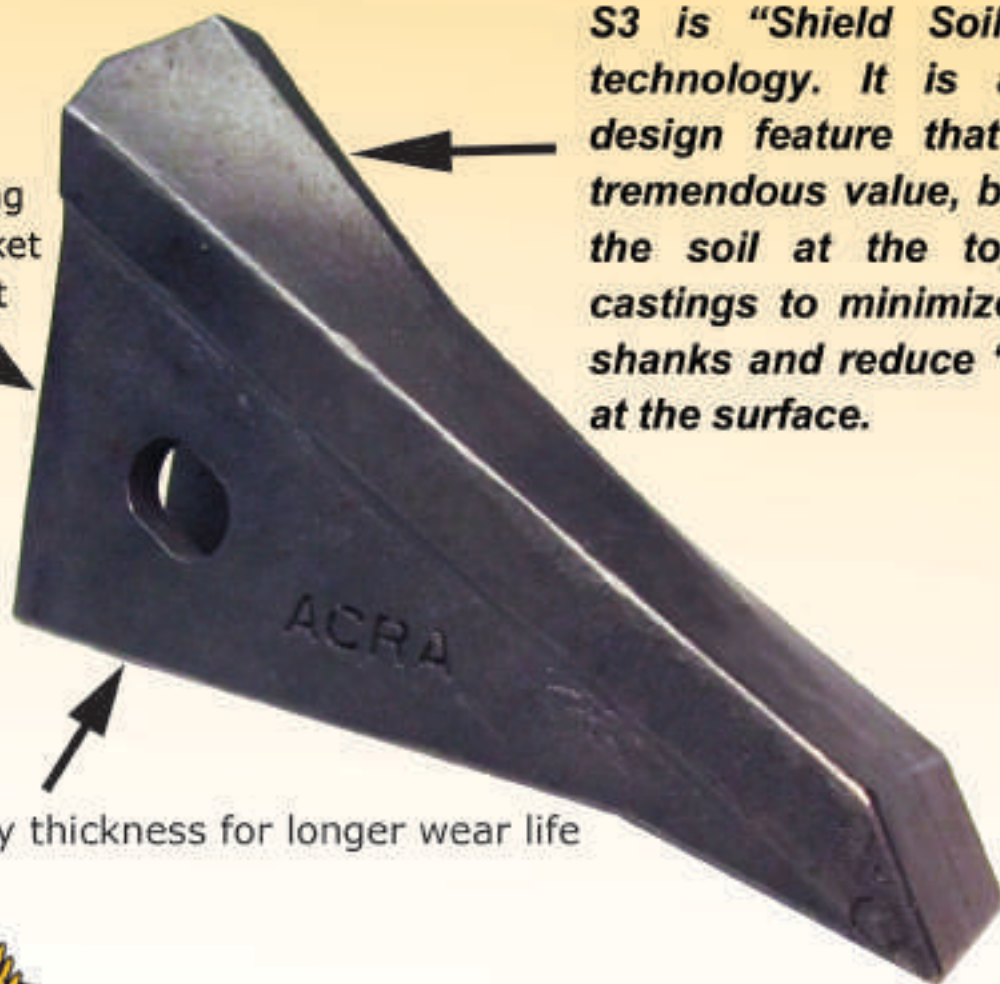

Increased body thickness for longer wear life



## [800] 798-1968

[www.shieldag.com](http://www.shieldag.com) [www.acraplant.com](http://www.acraplant.com)

PO Box 687 • Hutchinson, KS 67504-0687 • Fax (620) 662-7482

Item	DESCRIPTION AND MACHINE FIT	WEIGHT
AP-800207	RIPPER POINT w/PIN Big Ox Before 1986, casting # TF800207	3.33
AP-800500	V-CROWN RIPPER POINT FOR IHC#14 w/PIN, casting # 800500	6.33
AP-800601	RIPPER POINT w/PIN 1.25" SHANK JD/BH, casting # 8006-01	6.33
AP-800700	RIPPER POINT w/PIN Caldwell/Graber, casting # TF800700	8.5
AP-800800	RIPPER POINT w/PIN M&W Sunflower	5.5
AP-800850	RIPPER/Strip Till point, Redball, welded with chrome cap	3.8
AP-800900	RIPPER POINT w/PIN IHC #10 & #11 PAULK, casting # 800900	4.3
AP-801100	Terra-Flow point , casting # 801100 or ORP 3	4.5
TF-123	RIPPER POINT Tye/BighamBrothers, casting # TF123	6.1
TF-8006-011	SUBSOILER POINT 1" SHANK York Agri, casting # TF8006-011	5.5
TF-8006-011W	RIPPER POINT WINGED 1" SHANK woPIN, casting # TF8006-011W	7.4
TF-81322	BUSH HOG DORSAL FIN POINT	6.5
2D5	Big Ox Slip on point, NO Chrome Carbide	4.8
2D5B	Big Ox Slip on point, Chrome Carbide Cap	5.8
2D5BE	Big Ox Slip on point, Extended Chrome Carbide Cap	6.2



Item	REPLACEMENT HARDWARE	WEIGHT
AP-500646	5/16 X 2" Spirol (roll) pin	0.03
AP-500659	3/8 X 2" Spirol (roll) pin	0.02
AP-500771	1/2-13 X 3" Square head bolt	0.025
LW4	1/2" Lock washer	0.02
N4	1/2-13 Nut	0.02

ShieldAg.com 800-798-1968

BluJet Ripper points and shin guards

Item	Description	Weight	Fitup
AP-503200	BLUE JET OEM STYLE FALL POINT BJ3AFALL/5032	16	Same as BluJet Factory, except Chrome Carbide
AP-503300	BLUE JET OEM STYLE SPRING POINT BJ3ASPRING/5033	11	Same as BluJet Factory, except Chrome Carbide
AP-801300	BLUE JET SPRING POINT noHARDWARE, casting # TF801300	11	Acra Plant heavy duty replacement
AP-801400	BLUE JET FALL POINT noHARDWARE, casting # TF801400	16	Acra Plant heavy duty replacement
AP-801600	BLUE JET SHIN GUARD, reversible	14.5	Shin guard, chrome carbide
CRP-77	7" winged point	18	7" wide BluJet point, CRP wings

Acra-Plant points and shin guards are made from a special alloy of chrome carbide for long wear life and resistance to brittle failure

## Acra-Plant Chrome Carbide Subsoiler & Ripper Points

### Specialty Points for OEM Replacement

The Acra-Plant Line of Blu-Jet Points have been redesigned to optimize the fit, lower draft requirements, improve the attack angle and provide more protection of the shank bottom

#### Blu-Jet Sub Tillers

Part #	Description	Weight
AP-801300	Inner-row point (also considered "spring point") <ul style="list-style-type: none"> <li>• Narrow point for deep tillage</li> <li>• V-crown chrome carbide point scours up quickly and pulls easily</li> <li>• Point is 2" wide x 14" long</li> <li>• Casting # TF801300</li> </ul>	11.00

NOTE: Uses factory hardware, not supplied by Acra-Plant



AP-801300

Part #	Description	Weight
AP-801400	Wide point (also considered "Fall point") <ul style="list-style-type: none"> <li>• Wider point for deeper tillage, more shattering action</li> <li>• V-crown chrome carbide point scours up quickly and pulls easily</li> <li>• Designed to run "nose-down" for optimum performance</li> <li>• Point is 2-7/8" wide x 15-1/2" long</li> <li>• Casting # TF801400</li> </ul>	16.00

NOTE: Uses factory hardware, not supplied by Acra-Plant



AP-801400

Part #	Description	Weight
AP-801600	Shin guard for Blu-Jet sub tiller <ul style="list-style-type: none"> <li>• Improved casting chemistry to resist breakage</li> <li>• Guard is 1-1/4" wide x 22" long</li> </ul>	14.50

NOTE: Uses factory hardware, not supplied by Acra-Plant



AP-801600

Part #	Description	Weight
AP-503300	Blu-Jet Spring (OEM) <ul style="list-style-type: none"> <li>• Replaces casting # BJ3ASPRING/5033 or AP5033</li> </ul>	7.0
AP-503200	Blu-Jet FALL (OEM) <ul style="list-style-type: none"> <li>• Replaces casting # BJ3AFALL/5032 or AP5032</li> </ul>	13.6



AP-503200



AP-503300



## Chrome Carbide Shank, Sweep, Ripper and Harvesting Equipment Repairs

Segmented flat and half-round weld-on sectional guards

Part #	Size	Style	Typical Application	Weight
SG-111-9	1" X 9" long	Flat	3/4" ripper shanks	0.9
SG-114-9	1-1/4" X 9" long	Flat	1" ripper shanks	1
SG-112-9	1-1/2" X 9" long	Flat	1-1/4" ripper shanks	1.1
SG-175-7	1-3/4" X 7" long	Flat	1-1/2" ripper shanks	1.1
SGR-114-14	1-1/4" X 12" long	half round	1" ripper shanks	1.1
SGR-112-14	1-1/2" X 12" long	half round	1-1/4" ripper shanks	1.2

Edge Guards

Part #	Size	Style	Typical Application	Weight
SI-12	1" X 14" long	V-nose	Potato & peanut digger	1.11
SI-12HD	1-3/4" X 12" long	V-nose	Potato & peanut digger	2.17
SGT-12X 1/2	1/2" X 12" long	Triangle	harrow tynes & renovators	0.46
KTWS-01	9/16" X 6" segmented	Triangle	knife shank, edge guard	0.34
KTWS-02	3/4" X 6" segmented	Triangle	knife shank, edge guard	0.44
KTWS-05	9/16" X 6" segmented	Tapered triangle	knife shank, edge guard	0.33

Caps and other protectors

Part #	Size	Style	Typical Application	Weight
TF-147L	3" X 6" X 15 degrees	parallelogram	Left hand shank protector	1.6
TF-147R	3" X 6" X 15 degrees	parallelogram	Right hand shank protector	1.6
F-234-4	2-3/4" X 4" long	flat rectangle	ripper cap, shin protector	0.97
F-278-12	2-7/8" X 12"	flat rectangle	ripper cap, shin protector	3.85
B-178-6	1-7/8" X 6" long	bulb nose rectangle	ripper cap, shin protector	1.7
B-238-12	2-3/8" X 12" long	bulb nose rectangle	ripper cap, shin protector	3.5
B-278-12	2-7/8" X 12" long	bulb nose rectangle	ripper cap, shin protector	3.88
BE-238-7	2-3/8" X 7" long	hook nose rectangle	ripper cap, shin protector	2.25
BE-278-12	2-7/8" X 12" long	hook nose rectangle	ripper cap, shin protector	4.1
TFN-1002	3" step pocket V	open top point	sweep & chisel tip	0.29
TFN-1006	3" X 4-3/4"	HD closed top	chisel point	1.04

DO IT YOURSELF WELDING REPAIRS, Stoody STUBS sold by the pound, minimum 25 lb order, wire by full spools only

Part #	Size	Style	Typical Application	Weight
STUBS	1/4" dia X 12--18" long	Stoody hardface rod	manual oxy-acetylene hardfacing	2--4 lbs
11943400	.062" dia wire	hardface wire 101-HD	Mig weld hardfacing	33

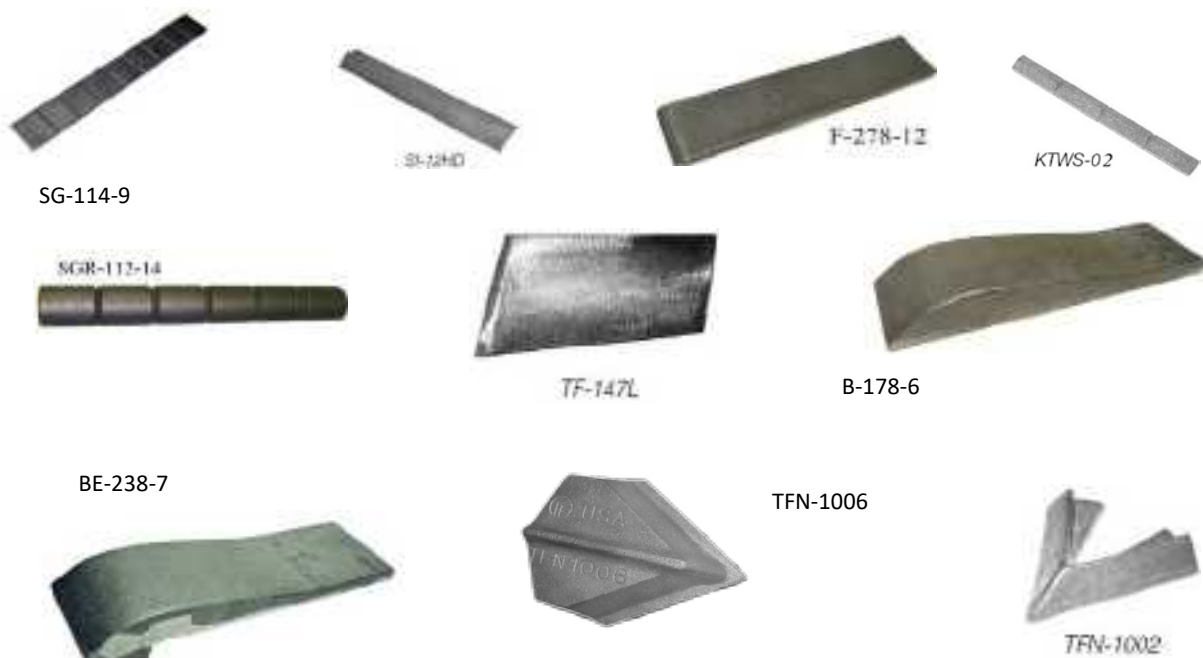

# ShieldAg Brand Names You've Trusted for Many Years

## ShieldAg

- Primary and Conservation Tillage
- Fertilizer Application Equipment
- Grain Drill and Planter parts
- U-bolts and Hardware
- Subsoiler Points

## Acra-Plant

- No-Till and Min-Till planter and grain drill retrofit parts
- Long-wear specialty sweeps and points
- V-Shot Starter Fertilizer kits
- V-slice Inserts
- Chrome Carbide Hoe Drill and suboilier/disc ripper points
- Acra Fertilizer Knives for Conventional and Chisel Plow applicators
- 2 X 2 on-Planter Placement with Trash Whippers and Zone Managers
- Acra Drill Unit ADU Assemblies and Service

## ShieldAg Conveyors

- High-speed, gentle handling of all grains
- Grain Piling systems
- Fertilizer/Sand/Salt and specialty crops

## ABM Milo guards & Brittan Crop Savers

### And we have ADDED:

**ARRO** Corn Head Retrofits for Milo and Sunflower Harvest

**EZE-LATCH** Gooseneck Trailer Products

## Baler and Conveyor Belting

**[www.shieldag.com](http://www.shieldag.com) 800-798-1968**

Shield P/N	Grain Drill disc assemblies, except where noted	OEM P/N or MODELS	DIAMETER	WEIGHT
13505	Great Plains 13-1/2", 3.5mm with 205 brg	107-135S and 107-138S	13-1/2"	6.25
13505N	13-1/2", 3.5mm with 205 brg, NOTCHED	GP and others	13-1/2" notched	6.1
SH13505	Great Plains 13-1/2", boxed set of two, shims + dust covers	107-135S and 107-138S	13-1/2"	15
SH13505N	13-1/2" NOTCHED, boxed set of two, shims + dust covers	GP and others	13-1/2" notched	14.5
SH13505TS	Great Plains 13-1/2", boxed set of two, shims + trash shields	GP and others	13-1/2"	14.6
15005GP	Great Plains 15", 4mm with 205 brg	404-121S and 404-0725	15"	7.5
SH15005GP	Great Plains 15", boxed set of two, shims + dust covers	404-121S and 404-0725	15"	16.5
13505	Crustbuster 13-1/2", 3.5mm with 205 brg	863597 for model 3800	13-1/2"	6.25
SH13505	Crustbuster 13-1/2", boxed set of two, shims + dust covers	863597 for model 3800	13-1/2"	15
15005GP	Crustbuster 15", 4mm with 205 brg	859090	15"	7.5
15005N	Crustbuster 15" notched, 4mm with 205 brg	N/A	15" notched	7.4
SH15005N	Crustbuster 15" notched, 4mm with 205 brg, boxed set of 2	N/A	15" notched	16
13505K	Krause 13-1/2", 3.5mm with 205 brg	No-till and Pro	13-1/2"	6.25
13505	Krause 13-1/2", 3.5mm with 205 brg	No-till and Pro	13-1/2"	6.25
15005SUN	Sunflower 15", 4mm with 205 brg	SN9753 & SN8358	15"	7.5
15005SFOB	Sunflower 15", 4mm with 205 brg	SN6483, 7261 & 18476	15"	7.5
DD13.5RC	Deere domed 13-1/2", DISC ONLY	N283805, N164594	13-1/2"	5.5
18-DD6-3	Deere air seeder 18", DISC ONLY	N283804, N214190	18"	14.5

Shield P/N	Row crop planter disc assemblies	OEM P/N	DIAMETER	WEIGHT
AP-JDF15D	Deere XP, XPRO EXTREME-duty cast steel hub, dbl 204	AA65248	15"	9.5
AP-7000MAXE15	Deere Max Emerge/Kinze 2000 HD single 204 brg	AA53860, exact OEM	15"	7.1
AP-7000MAXE15	Kinze 2000/3000 HD single 204 brg	GA8324, exact OEM	15"	7.1
AP-1700XP15	Deere XP, XPRO HD double row 204 brg	AA65248, exact OEM	15"	7.4
AP-1200-14-HDL	CaseIH 14" LEADING 4.5mm bevel OUTSIDE, HD 304 brg	84416318-L, 47828498	14"	8.2
AP-1200-14-HDT	CaseIH 14" TRAILING 4.5mm bevel INSIDE, HD 304 brg	84416319-T, 47828499	14"	8.2

\*\*\* Case discs are Heavy-Duty 4.5mm steel, replace mounting bolts with CaseIH HD bolt kit (longer bolts)

ALL Notched planter openers require the use of V-slice or V-shot planter inserts !

Shield P/N	ACRA PLANT DISC ASSEMBLIES, NOTCHED 15" NO-TILL	OEM P/N	DIAMETER	WEIGHT
AP-001711	Deere, Kinze 4mm HD 205 brg 11-notch	AP1711	15"	10.5
AP-001715	Deere, Kinze 4mm HD 205 brg 15-notch	AP1715	15"	10.5
AP-301151	Acra-Plant 15" ADU blade, 4mm domed HD 11-notch	301151	15"	10.5
AP-301152	Acra-Plant 15" ADU blade, 4mm domed HD, 15-notch	301151	15"	10.5

Shield P/N	Parts for disc assemblies	OEM P/N	WEIGHT
205DUST COVER	Dust cover for most 13-1/2" and 15" drill discs	Most OEMs	0.012
TRASH SHIELD	Trash shield for most 13-1/2" and 15" drill discs	Most OEMs	0.015
SHIM	Standard 1" OD X 5/8" ID X .06" thick shim	ALL OEMs	0.005
205DDS-C	Heavy-duty 205 Drill disc bearing	188-001V, 40-172	0.7
AP-ME51969	Heavy-duty double row 204 planter bearing, XP, ME5, XPRO	AA59196	1
203KRR-2DGE	Heavy-duty bearing for DD13.5RC drill discs	AN142670, JD9214, 822-095C	0.7



# Deere 1830 & 1835

## Air Hoe Drills

- AP-701830 direct replacement for Deere Factory AA77749, with tungsten tip
- AP-720012 Acra-Style Eagle Beak with V-slice technology



AP-701830  
Includes Pin



AP-701830 INSTALLED



AP-720012 (Z12)  
Includes Pin



AP-720012 INSTALLED

**Acra Plant has 40-years of hoe drill point design,  
and now we have the same style for late model Deere Air Seeders:  
AP-720012 Acra-point yields these benefits!**

- Uniform wear, part retains its whole shape through useful life to assure consistent performance
- Wear ridges to match the boot, to avoid premature scuffing of the expensive machine boot
- V-slice technology to improve seed-to-soil contact
- Will take the ground and penetrate to depth easier
- Scours up and pulls easy, with optimum soil flow for your press wheels to follow
- Less expensive than the tungsten-tip point



**ALL HOE DRILL POINTS ARE ORIGINAL ACRA-PLANT "Acra-Tuff" ALLOY**

PART #	DESCRIPTION	WEIGHT
AP-701830	Air hoe seeder point Deere 1830 and 1835 air drills, Tungsten Carbide tip	1.8
AP-710060	(DSZ6, Z6) bolt-on V-bottom, with hardware	0.8
AP-710070	(DSZ7, Z7) pin-on V-slice with pin	1.0
AP-710080	(DSZ8, Z8) pin-on V-slice with pin	1.2
AP-720011X	(Z11X) bolt-on extreme conditions, without hardware	0.9
AP-720012	Z12 Acra-Style V-bottom Air hoe seeder point Deere 1830 and 1835 air drills	1.2
AP-729390	(Z9, TF132) bolt-on drop-nose without hardware	0.9
AP-729400	Bolt-on V-bottom, drop-nose without hardware	0.9
AP-729410	(Z10, 657PO, TF105) pin-on without hardware	0.8
DNC-657D	(657) bolt-on Spear, without hardware	0.8
DNC-657DEB	(657DEB) drop nose bolt-on, without hardware	0.8
DNC-657V	(657V) B-bottom bolt-on Spear, without hardware	0.9
DNC-715V	(715V) economy bolt-on shallow V, without hardware	0.7
DNC-720011XV	(809V) bolt-on V-bottom point, without hardware	1.0
HARDWARE P/N	Description	Weight
AP-510693	5/16 X 1" Spring pin	0.01
N1	1/4-20 Square nut	0.01
Z1-1	1/4-20 X 1" Machine Screw slotted flat head	0.01
Z1-3	1/4-20 X 1-1/2" Machine Screw slotted flat head	0.015
1-1	Box of 100ea 1/4 X 1" and 1/4" Square nut	5

**ACRA HOE DRILL SHOES**

ASSEMBLY #	JD LZ and 9300	WEIGHT
AP-711052	JD LZ, 9300 Hoe drill shoe body only <b>WITHOUT POINT</b>	3.1
AP-711070	Acra Hoe drill shoe w/ Z7 point, JD LZ, 9300, 775-785 Air Hoe Drill, <b>WITH POINT</b>	4.1
ASSEMBLY #	Caselh 150 Cast Boot	WEIGHT
AP-715052	Caselh 150 Cast Boot Hoe drill shoe body only <b>WITHOUT POINT</b>	2.5
AP-715070	Acra Hoe drill shoe w/Z7 point, Caselh 150 cast boot, <b>WITH POINT</b>	3.5
ASSEMBLY #	JD 9400 and 1800-series air hoe seeder	WEIGHT
AP-719452	JD 9400 Hoe drill shoe body only <b>WITHOUT POINT</b>	3.8
AP-719480	Acra Hoe drill shoe w/Z8 point, JD 9400 & 1800-series Air hoe air seeder, <b>WITH POINT</b>	5.0

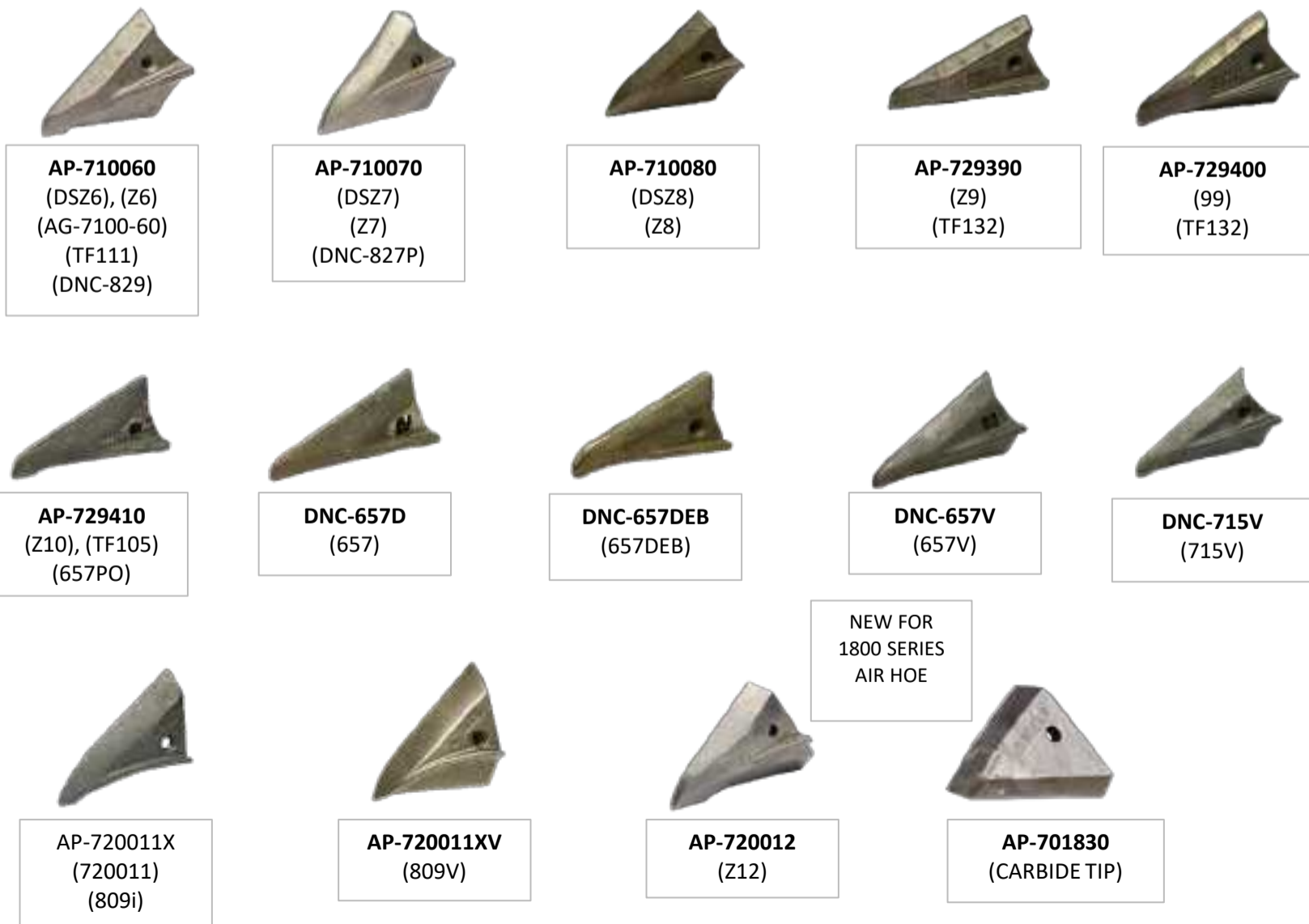

**INNOVATION IN PRECISION AGRICULTURE**

**STRAIGHT FROM THE HEARTLAND**

**MADE IN THE USA**



**US PATENT # 9,675,005**

*ShieldAg/AcraPlant offers precision seed placement WITH starter fertilizer*

**DEERE XP**



**EARLY DEERE & KINZE**



**WHITE**



**KINZE 3000**



**KINZE 4000**



**CASE IH**



### **V-Shot**

- V-slice proven technology, improving seed-soil contact
- Uniform and early emergence, eliminate seed roll-and-bounce
- Apply starter fertilizer WHERE IT BELONGS, below the seed
- All these benefits with 1 tool



All complete kits have Suggested Retail Price of \$119.95 per Row

Acra-Plant Kit Number	Brand	Acra-Plant V-SHOT kits Designed for	Approximate Planter Production years	Casting and SS tube in the kit	
				Casting #	SS tube #
AP-7100V-SHOT	Deere	7000 and 7100 Max Emerge built before 1984 and Kinze 2000	1977--1984	AP-001785VS	AP-001785VS-W
*Original part number: AP-1785V-SHOT-7100				Casting #	SS tube #
AP-7184V-SHOT	Deere	7000 and 7100 Max Emerge built in 1984, 85 and early 86	1984--1986	AP-001785VS	AP-001785VS-WO
*Original part number: AP-1785V-SHOT-7184				Casting #	SS tube #
AP-1785V-SHOT	Deere	7200 and later ME2, ME PLUS and ME-PRO planters, including 1700-series prior to 2004 with ME+ or PRO row units, and 1530 and early 1535 Drills with ME row units.	1986--2004	AP-001785VS	AP-001985XPVS-W
				Casting #	SS tube #
AP-1985V-SHOT	Deere	XP, XP Pro and MaxEmerge® 5 ME5 row units ***DOES NOT FIT EXACT EMERGE	2005 to present	AP-001985XPVS	AP-001985XPVS-W

**Shorter Version of 1985XP V-shot that does NOT hang as far below the blades, for tough clay conditions AP-1985V-SHOTG**

Acra-Plant Kit Number	Brand	Designed for	Approximate Planter Production years	Casting #	SS tube #
AP-1985V-SHOTG	Deere	XP, XP Pro and MaxEmerge® 5 ME5 row units	2005 to present	AP-001985XPVSG	AP-001985XPVS-W
***Consult factory for details !!!				Casting #	SS tube #
***DOES NOT FIT EXACT EMERGE					

Acra-Plant Kit Number	Brand	Designed for	Approximate Planter Production years	Casting #	SS tube #
AP-7100V-SHOT	Kinze	Kinze 2000, same kit as for early JD ME 7000/7100	All Kinze 2000 models 1999 & older	AP-001785VS	AP-001785VS-W
*Original part number: AP-1785V-SHOT-7100				Casting #	SS tube #
AP-4985V-SHOT	Kinze	Kinze 4900 (4000-series row units)	Introduced in 2014	AP-004985VS	AP-001785VS-W
				Casting #	SS tube #
AP-1690V-SHOT	White	White 9000 series ** Planter has 16" discs, requires different V-SHOT	Introduced in 2014	AP-001690VS	AP-001690VS-W

Acra-Plant Kit Number	Brand	Designed for	Approximate Planter Production years	Casting and SS tube in the kit	
				Casting #	SS tube #
AP-1885V-SHOT	Kinze	Kinze 3000	Introduced in 1999 for 2000 --2014	AP-001885VS	Not required
AP-1885V-SHOTG	Kinze	Kinze 3000, shorter version	Introduced in 1999 for 2000 --2014	AP-001885VSG	Not required

The V-SHOTG does not hang as far below the blades, for tougher dry or clay conditions, order the AP-1885V-SHOTG

Acra-Plant Kit Number	Brand	Designed for	Approximate Planter Production years	Casting and SS tube in the kit	
				Casting #	SS tube #
AP-1685V-SHOT	White	White 6000 and 8000 series	Approximately 1990--2014	AP-001685VS	AP-001785VS-W
AP-9885V-SHOT	CaseIH	CaseIH 1200 series and later	Approximately 2000--2015	AP-009885VS	Not required

**\*\*\*Installation of the AP-9885V-SHOT for CaseIH planters requires drilling a 9/32" hole through the trailing disc lip of the center disc support**

**\*\*\*Complete set of instructions and drilling template is furnished with each kit, and a video is available on the ShieldAg YOUTUBE page**

<https://www.youtube.com/watch?v=RofCqdxk4U> ← Location on YouTube

**\*\*\* AP-9885V-SHOT will also work with CaseIH 800- and 900-series planters, consult Acra-Plant to confirm planter center body design**

**ShieldAg.com 800-798-1968**

All complete kits have Suggested Retail Price of \$119.95 per Row

**Acra Plant V-slice Inserts, see V-SHOT Catalog Section for precision in-furrow V-shots**

Item	Description	Weight
AP-001685	V-SLICE INSERT w/PIN/BOLT White 6000 Series and Later NON V-SHOT	1.9
AP-001785	V-SLICE INSERT w/PIN/BOLT John Deere & Kinze 2000 NON V-SHOT	2.0
AP-001785CLIP	Plastic seed tube clip for Deere 7000, Kinze 2000 NON V-SHOT	0.1
AP-001885	KINZE 3000 SERIES V-SLICE OPENER NON V-SHOT	2.0
AP-001985XP	V-SLICE INSERT John Deere XP Row Units NON V-SHOT	2.2
AP-009885	V-SLICE INSERT CaseIH 800, 900 and 1200 series	1.8
AP-331100	ADU INSERT JDI3 w/Bolts/Nuts for Acra Drill Unit	1.9
AP-410000	OPENER SLICING BLADE w/BOLT/NUT 10-C for tandem blade opener	2.2
AP-410100	OPENER SLICING STUB w/JBOLT V-9 & tandem opener	1.0
AP-954141	ACRA PLANT OPENER W/J-Bolt 7-C for Lister Opener	1.3



AP-009885 standard Acra-Plant Chrome Carbide V-slice to replace OEM CaseIH seed firmer for 800-900-1200 series



**NEW PRODUCT  
INTRODUCED IN 2019 !!!**

ALL ACRA V-SLICERS ARE MADE USING THE ORIGINAL ACRA-TUFF CHEMISTRY, a PROPRIETARY ALLOY  
Ask for ORIGINAL ACRA V-slicers for your planter, grain drill or lister !!  
For IN-furrow pop-up starter fertilizer application with your V-slice inserts, SEE our V-SHOT page in this catalog !!

ShieldAg.com 800-798-1968



ITEM NO.	PART NUMBER	DESCRIPTION	QTY			AP-300527	ADU GREASELESS HINGE BUSHING	4
1	AP-301151	15"ADU OFFSET DISC ASSY, 11 NOTCH	1	18	AP-300537	ADU NYLATRON BUSHING		4
2	AP-301152	15" ADU OFFSET DISC ASSY, 15 NOTCH	1	20	AP-300039	ADU SPRING ANCHOR BAR		1
3	AP-301111	15" OFFSET DISC ONLY, 11 NOTCH	1	21	AP-500512	5/8-11 X 4-1/2" ALL THD HEX BOLT GR 5		1
4	AP-301115	15" OFFSET DISC ONLY, 15 NOTCH	1	22	AP-300133	DOUBLE HOOK SPRING		2
5	AP-301103	ADU SEED TUBE, STEEL	1	23	AP-500541	J-BOLT, 2" X 9/16" X 3/8-16		2
6	AP-500448	5/16-18 X 3/4" BTN HD SOC	12	24	AP-305135	PRESS WHEEL DEPTH ADJUSTMENT		1
7	AP-299050	BEARING FLANGE GASKET	2	25	AP-300412	PRESS WHEEL WELDMENT, SINGLE		1
8	AP-698051	BEARING RETAINER RING	2	26	AP-500557	PULL PIN WITH CLIP, 4"		1
9	AP-301155	ADU DISC BEARING, 5/8" BORE	2	27	AP-510503	5/8-11 X 3-1/2" HEX BOLT GR 5		1
10	AP-299143	BEARING FLANGE	2	28	AP-510712	PRESS WHEEL, 2" X 13", SMOOTH CRWN		1
11	AP-500582	5/16-18 TOP LOCK NUT	12	29	AP-500328	ADU PRESS WHEEL SPACER		1
12	AP-299041	ADU DUST COVER	2	30	AP-510597	5/8-11 TOP LOCK NUT		1
13	AP-500510	5/8-11 X 2-1/2" HEX BOLT GR 5	1	31	AP-300413	PRESS WHEEL WELDMENT, DOUBLE		1
14	AP-500506	5/8-11 X 2-1/2" LH HEX BOLT, GR 5	1	32	AP-510716	5/8-11 X 6-1/2" HEX BOLT GR 5		1
15	AP-300196	ADU MAIN SPRING	1	33	AP-501540	ADU PRESS WHEEL SPACER		2
16	AP-300055	ADU MAIN SPRING NUT	1	34	AP-510723	PRESS WHEEL, 4" X 12" V-GROOVE		1
17	AP-300041	ADU SPRING ANCHOR PLATE	2	36	AP-331100	ADU INSERT W/ BOLTS & NUTS		1

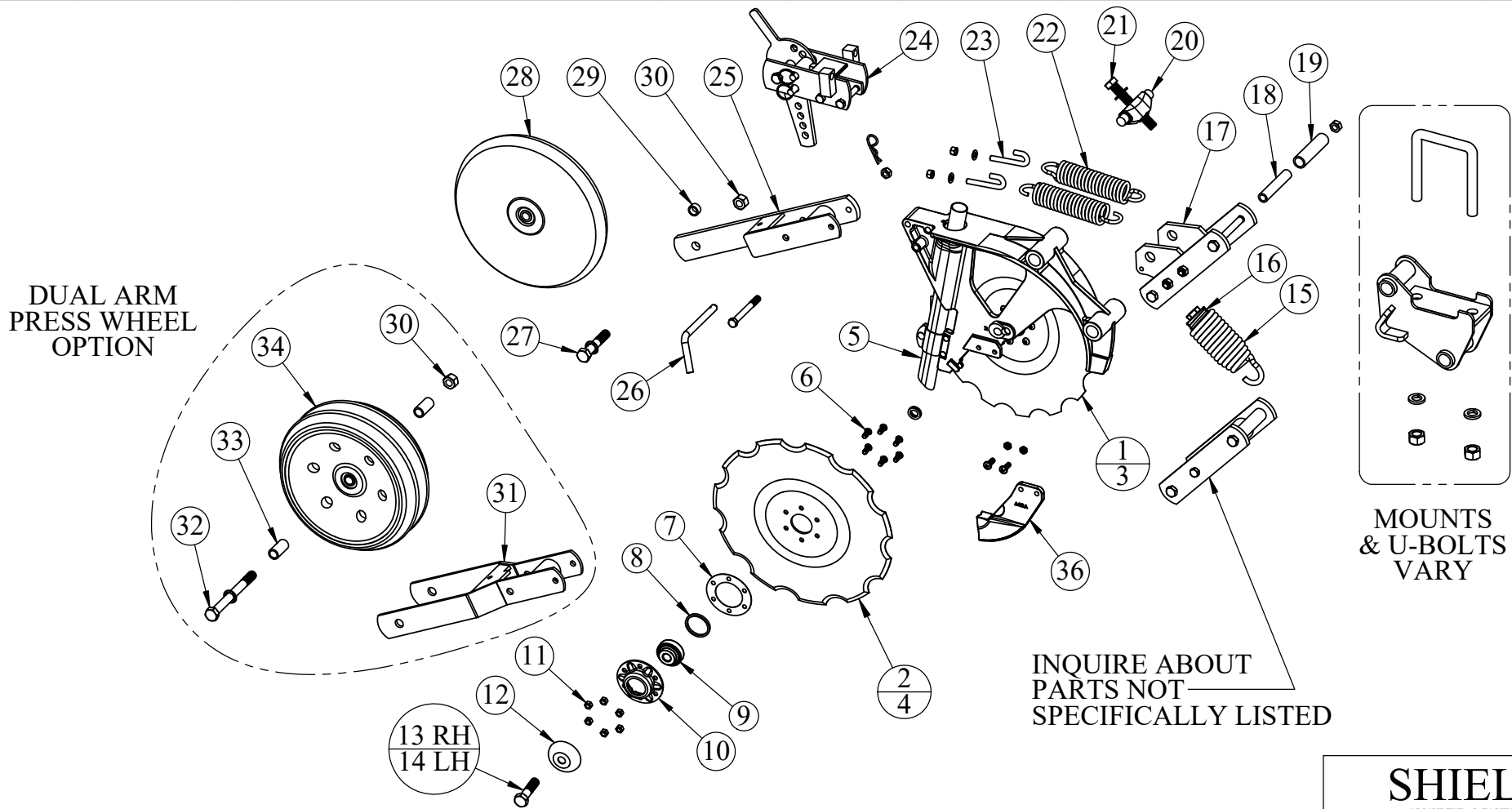

DESCRIPTION STANDARD ADU LAYOUT	MATERIAL ASSEMBLY	DO NOT SCALE DRAWING	PART NO. ADU LAYOUT 27	REV. NC
		Weight: 110 LBS		

**SHIELD**  
AGRICULTURAL EQUIPMENT

**COMPLETE ROW UNITS AND COMPONENTS AVAILABLE TO FIT ALL TOOLBAR SIZES**

Part Number	Coulter mounts and coulter arms for toolbars	WEIGHT
KSC-466340S	Cast Steel 4 X 4 or 6 X 4 Coulter System Mount, requires 3/4" mtg hdwre	10.0
KSC-466360	20" Coulter Arm with shaft and 20" smooth blade	77.0
KSC-466370	24" Coulter Arm with shaft and 24" smooth blade	90.0
KSC-466670	Cast steel 5 X 7, 7 X 7, 4 X 6, 6 X 6 Coulter Mount, requires 3/4" mtg hdw	20.0
KSC-531002	20" Liquid Coulter Arm w/ shaft and 20" fluted crucible blade	91.0
KSC-531002LH	20" LEFT HAND Liquid Coulter Arm w/ shaft and 20" fluted crucible blade	91.0
KSC-666460	Berm conditioner for 1 X 2 or 1-1/4 X 2 flat-way shanks, convex basket	65.0
KSC-666461	Berm conditioner for 1 X 2 or 1-1/4 X 2 flat-way shanks, concave basket	65.0



Berm conditioner baskets available for about any toolbar shank-style !!

**Building or repairing a toolbar?**

- \*Side dress or liquid bar
- \*Strip till
- \*Conventional applicator
- \*Chisel bar

ShieldAg has all of the components needed below the toolbar !!!  
 Many components are not listed here,  
 just call us if you are repairing or rebuilding your toolbar !

Part Number	Anhydrous bar disc sealers	WEIGHT
KSC-441100	Sealer assy with 2ea 18DB11-NO (blades) and U-bolts 1 X 2 flat shanks	70.0
KSC-441200	Sealer assy with 2ea 18DB11-NO (blades) and U-bolts edge-bent shanks	70.0



Disc sealer assemblies are shipped "nearly fully assembled"  
 5 different sealer blade types are available  
 from 14" smooth to 17" wavy to 18" notched or smooth

Fertilizer toolbar shanks are 100% Made In USA using domestic 5160 chromium manganese steel !  
**Coil shanks and Flat-way shanks to fit most modern toolbars !**

Part Number	SHANKS	WEIGHT
KSC-90	DMI Shank 1-1/4" square	30.0
KSC-91	Clark 3 Hole Front Mount, 1-1/4" square	34.0
KSC-92	Wilmar or Dempster, 1-1/4" square	32.0
KSC-93	TCl Stubby Shank, 1-1/4" square	31.0
KSC-94	Universal 1 Hole, 1-1/4" square	30.0
KSC-95	Titan or Blue Jet, 1-1/4" square, most common coil shank	33.0
KSC-96	Champion Shank, 1-1/4" square	31.0
KSC-97	John Blue Long, 1-1/4" square	32.0
KSC-98	John Blue Short, 1-1/4" square	30.0
KSC-1290	DMI Flat Shank, 1 X 2, no soil end holes	19.0
KSC-1295	Flatten Side Blue Jet, 1 X 2 BluJet flat way shank, NOT edge bent	20.0
KSC-1298	Flatten Side Mount DMI, 1 X 2 standard shank, NOT edge bent	22.0
KSC-1298WP	Flatten Side Mount DMI w/Locating Pin	22.0
KSC-1299	Flatten Side Mount DMI, HEAVY DUTY 1-1/4 X 2"	28.0
KSC-1315	Chisel plow Shank, HEAVY DUTY 1-1/4 X 2"	27.0

SHANK DIMENSIONS AVAILABLE UPON REQUEST



Part Number	Lollipop shank mount eyebolts	WEIGHT
KSC-384i1142	4" bar Eye Bolt w/hdwre for 1-1/4" square, 1x2" or 1-1/4 X 2 shanks	1.3
KSC-386i6	6" bar Eye Bolt w/hdwre for 1-1/4" square, 1x2" or 1-1/4 X 2 shanks	1.5



**Eyebolt clamp sets available to fit all standard toolbar sizes, call us or a rigid clamp to suit your application**

Shield manufactures and stocks 100's of NH3, liquid and dry applicator SHANKS, KNIVES, TOOLBAR MOUNTS, CLAMPS and other repair parts. Ask your TM for details !

**IF YOU DON'T SEE IT HERE, we probably DO HAVE IT, just ASK !!!**

### Acra Plant Side Mount Quick Change Fertilizer Knives and Parts

Item	Description	Weight
AP-711	Acra Knife Shank w/ 3/8" NH3 tube (.408" OD, for 3/8" NH3 hose), no point, Replaces AP-700010	4.6
AP-711/3/4DA	Acra Knife Shank w/ 3/8" NH3 tube and 3/4" Vapor Tube, no point, Replaces AP-700010V	5.4
AP-700041	STANDARD ACRA KNIFE POINT w/PIN	4.3
AP-700043	ACRA HEAVY DUTY SUPER WING POINT WITH PIN	4.4
AP-700042-ST	Strip Till Point Acra Knife Series	4.0
AP-700044	ACRA CLOSER POINT w/PIN	3.8
AP-700020	Replacement Tube 3/8" NH3	0.5
AP-700021	Replacement Tube 3/8" open-end liquid	0.5
AP-700022	Replacement Tube 1/2" open-end liquid	0.6
AP-700023	Replacement 3/8" NH3 tube with RINGS welded for 1/2" Liquid/Vapor	0.6
AP-700025	Replacement Tube 1/2" NH3	0.6
SA-700011	Acra Knife Shank w/ NO Tube	4.5
K2TBDA3/4	Replacement 3/4" Vapor tube (Raven)	0.7
AP-510674	3/8 X 1-3/8" spring pin	0.1

All Acra-Plant fertilizer knives and replacement points have been improved for longer wear life and durability in modern high-horsepower environments !  
 All types of fertilizer tubes and knife configurations, including dry fertilizer, are now available.  
 Call us for a quote on your special application !!!



ACRA PLANT  
FERTILIZER KNIFE  
WITH AP-700041



AP-700042-ST  
STRIP TILL



AP-700043  
HD conventional



AP-700044  
SUPER SEALER

### Acra Plant Chisel Plow Fertilizer Knives and Parts

Item	Description	Weight
AP-705011	Nickel Alloy Chisel Plow Shank	4.40
AP-705020	3/8" NH3 tube (.408" OD), crimped and drilled	0.32
AP-705021	3/8" Liquid tube (.408" OD), open end	0.32
AP-705022	1/2" open-end liquid tube	0.34
AP-705023	3/8" NH3 tube with RINGS welded for 1/2" Liquid/Vapor	0.46
AP-705024	1/2" NH3 tube	0.34
AP-705029	Tube Mounting bracket kit	0.50
AP-705042	Enhanced Chrome Alloy Fertilizer Point w/pin	4.10
AP-705141	Chrome Alloy Chisel Plow Point with pin	3.88
AP-708003	Adjusting Wedge for AP-705000	0.50
AP-708041	Improved "old-style" fertilizer point, replaced by AP-705042, but still available, w/pin	2.80
AP-510673	1/2" X 1-1/4" spring pin	0.10

Convert your chisel plow to an efficient fertilizer applicator !!!  
 With interchangeable points, you can go from fertilizer application to standard chisel operation in minutes by just changing the tip !!



ACRA PLANT  
CHISEL



AP-705011  
Alloy shank



AP-705042  
Fertilizer point,  
improved version  
of AP-708041



AP-705141  
Chisel point

AP-708041  
Revised old-style  
fertilizer point is still  
available !



CPK-1E



CPK-1E/3/4DA



Heaviest chrome carbide wear point in the industry !  
 Universal front mount using plow bolts to fit just about any chisel shank out there !

ShieldAg manufactures over 450 different NH3, liquid, dry and combination fertilizer knives--ask your TM for details !

Part Number	CHISEL PLOW	WEIGHT
CPK-1E	Single 3/8" NH3 tube w/ trash guard, CHISEL PLOW	6.2
CPK-1E/1/2A	Single 1/2" NH3 tube w/ trash guard, CHISEL PLOW	6.3
CPK-1E/3/4DA	3/8" NH3 tube and 3/4" Vapor Tube w/trash guard, CHISEL PLOW	7.3

DF-1PM



DF-1PM/3/4DA



DF-1PM knives are 16" tall with universal mounting hole/slot  
 Self-sealing in most applications

When ordering, specify OPEN END or DRILLED primary fertilizer tubes

Part Number	Shield MOLE/Deep Furrow	WEIGHT
DF-1PM	Single 3/8" NH3 tube	7.2
DF-1PM/3/4DA	3/8" NH3 & 3/4" vapor tube	7.8
DF-1PM/DA	3/8" NH3 & 3/8" open end tubes	7.6
DF-1PM/DA/3/4	3/8" NH3 & 3/8" open end tubes and 3/4 vapor tube	8.4
DF-1PM/ST	Single 3/8" NH3 tube with Strip till protection STRIP TILL	10.3
DF-1PM/ST/3/4DA	3/8" NH3 & 3/4" open end tubes and strip till protection STRIP TILL	11.1

Shield offers a full line of patented Strip Till knives through our master distributors, please ask for details

K-2T

K-2T/3/4DA



K-2T knives use upright universal mounting shanks and are 15" tall to fit most standard fertilizer rigs



ShieldAg manufactures over 450 different NH3, liquid, dry and combination fertilizer knives--ask your TM for details !

Part Number	Upright conventional knives	WEIGHT
K-2T	Single 3/8" NH3 tube	6.2
K-2T/3/4DA	3/8" NH3 & 3/4" open end tubes	7.2
K-2T/3/4DA/PLSPL	3/8" NH3 & 3/4" open end tubes with sealer	7.8
K-2T/O	Single 3/8" open end tube	6.2
K-2T/O/3/4DA	3/8" OPEN & 3/4" open end tubes	7.2
K-2T/O/3/4DA/PLSPL	3/8" OPEN & 3/4" open end tubes with sealer	7.8
K-2T/O/PLSPL	Single 3/8" OPEN tube with sealer	7
K-2T/PLSPL	Single 3/8" NH3 tube with sealer	7

Side Dress Knives

K-5SBSST

K-7S  
tubeless



K-5F50  
Forged 13"  
Coulter knife



Patented !!

Part Number	Liquid applicator (side dress) knives	WEIGHT
K-33607014BB	Boron Steel thin knife for DMI coulter rigs, 3/8" open-end tube	4.2
K-33607014BBSST	Boron Steel thin knife for DMI coulter rigs, 3/8" tube w/SURFA-SHIELD	4.3
K-4TSBS/BSST	14" Tall Backswept, 3/8" Tube, 5/16" Boron steel w/SURFA-SHIELD	3.6
K-5SBSST	Boron Steel thin knife , 3/8" open end tube with SURFA-SHIELD	4.4
K-5SHDWREKIT	Hardware kit for thin knives, includes cushion	1
K-7S	Chrome knife for coulter systems, accepts 3/8" flex hose	5.5
K-5F50	Forged 3/8 X 13" side dress knife with 3/8" tube, NEW FOR 2018 !!	3.7

Call us if you don't see the side dress knife you want for your rig, we probably have one !!

ShieldAg.com 800-798-19687

K-4T



K-4T/3/4DA



16" tall front swept knives designed to "take the ground" in the toughest conditions. Universal shank mount is the same as our DF-1PM series knives.

ShieldAg manufactures over 450 different NH3, liquid, dry and combination fertilizer knives--ask your TM for details !

When ordering, specify OPEN END or DRILLED primary fertilizer tubes  
Front Swept knives

Part Number	Front Swept knives	WEIGHT
K-4T	Single 3/8" NH3 tube	6.6
K-4T/3/4DA	3/8" NH3 & 3/4" open end tubes	7.4
K-4T/DA	3/8" NH3 and 3/8" liquid	7.2
K-4T/DA/3/4	3/8" NH3 and 3/8" liquid with 3/4" vapor tube	8.0
K-4TS	Single 3/8" NH3 tube, SLIM NO-TILL	5.5
K-4TS/3/4DA	3/8" NH3 & 3/4" open end tubes, SLIM NO-TILL	6.5
K-4TS/DA	3/8" NH3 & 3/8" open end tubes, SLIM NO-TILL	6.4
K-4TS/DA/3/4DA	3/8" NH3 & 3/8" open end tubes and 3/4 vapor tube, SLIM NO-TILL	7.2

K-4TSDF



K-4TSDF/3/4DA



SHREW knives are min-till 3/8 X 2-1/2 knives made to give a little fracture and lift for good sealing without a lot of surface disturbance.

ShieldAg manufactures over 450 different NH3, liquid, dry and combination fertilizer knives--ask your TM for details !

Part Number	SHREW knives, miniature DF Mole knife	WEIGHT
K-4TSDF	SHREW with 3/8" drilled tube mini DF	6
K-4TSDF/DA	SHREW with 3/8" drilled and 3/8" open tubes	6.9
K-4TSDF/3/4DA	SHREW with 3/8" drilled tube and 3/4" vapor tube	7.1



TA-1

Fertilizer sweep tubes to fit just about any chisel, chisel plow sweep, row crop or field cultivator sweep !



TA-2



TA-3

Part Number	Sweep and chisel tubes to convert	WEIGHT
TA-1	Center Mount Chisel Plow and Sweep Tube	0.65
TA-2	Side Mount Chisel Plow and Sweep Tube	0.68
TA-3	Side Mount Sweep Tube for Chisel Plow Sweeps and Field cultivators	0.69





INNOVATION IN AGRICULTURE.

## HD PRY-BARS

Our HEAVY-DUTY pry-bars are the hottest thing going for farm equipment dealerships & small fab shops. Take advantage of this hot selling pair of pry-bars today.

### **SPB-1 DOUBLE HOOK BAR**

- Dimensions: 1x1x45"
- Weight: 13 Lbs

SHIELDAG

### **SPB-2 POINT BAR W/HOOK**

- 7" double taper
- Dimensions: 1x1x23"
- Weight: 6.5 Lbs

SHIELDAG

- 5160 Chromium-Manganese
- Heat Treated & Tempered
- 150,000 psi Strength
- Made in the USA

ShieldAg pry-bars are manufactured in the USA, from fine-grained, double-rolled 5160 chromium-manganese steel that's heated and tempered for 150,000 psi strength, durability and toughness that can't be matched.



Made in USA

STRAIGHT FROM THE HEARTLAND



**(800) 798-1968**  
**ShieldAg.com**

# ShieldAg Boxed Bolt & Nut Kits and bulk purchase bolts/nuts



PART #	Box of Bolts and Nuts	Box Quantity	Weight per box	BOLTS ONLY	Weight per 100
1-1	1/4-20 X 1" w/ square nut, drill points	100	2.3	Z1-1	1.6
1-3	1/4-20 X 1-1/2" w/ square nut, drill points	100	2.9	Z1-3	2.2
2-2	3/8-16 X 1-1/4 Plow Bolt/nut	100	5.8	Z2-2	4
2-3	3/8-16 X 1-1/2 Plow Bolt/nut	100	6.3	Z2-3	4.7
3-3	7/16-14 X 1-1/2 Plow Bolt/nut	50	5	Z3-3	6
3-4	7/16-14 X 1-3/4 Plow Bolt/nut	50	5.3	Z3-4	7.1
3-5	7/16-14 X 2 Plow Bolt/nut	50	5.6	Z3-5	8.2
3-7	7/16-14 X 2-1/2 Plow Bolt/nut	50	6.2	Z3-7	10.4
4-3	1/2-13 X 1-1/2 Plow Bolt/standard nut	50	6.5	Z4-3	8.7
4-3H	1/2-13 X 1-1/2 Plow Bolt/heavy nut	50	7.5	Z4-3	8.7
4-3JH	1/2-13 X 1-1/2 Plow Bolt/heavy JAM nut	50	6.5	Z4-3	8.7
4-4	1/2-13 X 1-3/4 Plow Bolt/standard nut	50	7	Z4-4	9.9
4-4H	1/2-13 X 1-3/4 Plow Bolt/heavy nut	50	7.75	Z4-4	9.9
4-4JH	1/2-13 X 1-3/4 Plow Bolt/heavy JAM nut	50	7	Z4-4	9.9
4-5	1/2-13 X 2 Plow Bolt/standard nut	50	7.5	Z4-5	11.3
4-5H	1/2-13 X 2 Plow Bolt/heavy nut	50	8	Z4-5	11.3
4-6	1/2-13 X 2-1/4 Plow Bolt/standard nut	50	8	Z4-6	12.4
4-6H	1/2-13 X 2-1/4 Plow Bolt/heavy nut	50	8.5	Z4-6	12.4
4-7	1/2-13 X 2-1/2 Plow Bolt/standard nut	50	9	Z4-7	14.1
4-8	1/2-13 X 2-3/4 Plow Bolt/standard nut	50	9.2	Z4-8	15.5
4-9	1/2-13 X 3 Plow Bolt/standard nut	50	9.5	Z4-9	16.8
4-91	1/2-13 X 3-1/2 Plow Bolt/standard nut	50	10	Z4-91	19.5
P/N	Plow Bolts with oversize heads				
H2-3	3/8-16 X 1-1/2 with 7/16" plow head w/Nut	100	5.9	ZH2-3	4.8
H3-4	7/16-14 X 1-1/2 with 1/2" plow head w/Nut	50	6	ZH3-4	6.2
H3-7	7/16-14 X 2-1/4 with 1/2" plow head w/Nut	50	7	ZH3-7	8

P/N	Grade 5 Nuts, purchase in bulk	Weight per 100
N1	1/4-20 Square Nut	0.7
N2	3/8-16 Hex Nut	1.6
N3	7/16-14 Hex Nut	2.8
N4	1/2-13 Hex Nut	4
N4H	1/2-13 Heavy Hex Nut	6.6
N4JH	1/2-13 Heavy Hex Jam Nut	4.1
N5	5/8-11 Hex Nut	7.4
N6	3/4-10 Hex Nut	12

**Please order BULK BOLTS  
and BULK NUTS in even  
Quantities of 100ea**

**ShieldAg Stocks  
1000's of Hex Bolts Too  
Ask us for a quote !!**

# SHIELDAG U-BOLTS

- ALL U-BOLTS ARE FURNISHED WITH NUTS AND LOCKWASHERS
- ZINC PLATED FOR CORROSION RESISTANCE
- ASME GRADE 5 FOR STRENGTH AND TOUGHNESS, WITHOUT BEING BRITTLE
- PULL-TESTED TO MEET ASME AND ASAE SPECIFICATIONS
- LARGE INVENTORY OF MOST COMMON SIZES

SHIELDAG U-BOLTS ARE MADE IN USA !!!



NOTE: ALL MEASUREMENTS ARE VERTICAL FIRST ( LEG LENGTH ) BY HORIZONTAL SECOND ( INSIDE WIDTH )

SIZE	PART NUMBER	DESCRIPTION, VERT X WIDTH X THREADS	TOOLBAR	LEG LENGTH	WIDTH	WEIGHT
1/4"	AP-500536	U-BOLT, 1 X 0.5625 X 1/4-20	N/A	1	9/16	0.06
5/16"	AP-500559	U-BOLT, 2.5 X 1.5 X 5/16-18	1.5X1.5	2 1/2	1 1/2	0.16
3/8"	AP-500541	J-BOLT, 2 X 0.5625 X 3/8-16	J-BOLT	2	9/16	0.12
	AP-500556	U-BOLT, 4 X 1.5 X 3/8-16	3X1.5	4	1 1/2	0.32
	AP-500561	U-BOLT, 5.25 X 4 X 3/8-16	4X4	5 1/4	4	0.35
	AP-500576	U-BOLT, 5 X 6.0625 X 3/8-16	4X6	5	6	0.44
	AP-500573	U-BOLT, 7 X 6 X 3/8-16	6X6	7	6	0.48
	AP-500562	U-BOLT, 7.25 X 4 X 3/8-16	6X4	7 1/4	4	0.50
	AP-500577	U-BOLT, 7.875 X 7 X 3/8-16	7X7	7 7/8	7	0.55
7/16"	AP-500575	U-BOLT, 6 X 5.125 X 7/16-14	5X5	6	5 1/8	0.65
1/2"	AP-500523	U-BOLT, 1.75 X 3.0625 X 1/2-13	N/A	1 3/4	3	0.40
	AP-505525	U-BOLT, 2.5 X 2 X 1/2-13	1X2	2 1/2	2	0.42
	AP-500525	U-BOLT, 3.25 X 2.0625 X 1/2-13	2X2	3 1/4	2	0.49
	AP-500527	U-BOLT, 3.25 X 6 X 1/2-13	2X6	3 1/4	6	0.68
	AP-305648	U-BOLT, 3.5 X 1.25 X 1/2-13	N/A	3 1/2	1 1/4	0.45
	AP-500526	U-BOLT, 4.375 X 2 X 1/2-13	3X2	4 3/8	2	0.58
	AP-500524	U-BOLT, 4.25 X 3.0625 X 1/2-13	3X3	4 1/4	3	0.62
	AP-505528	U-BOLT, 4.25 X 5.0625 X 1/2-13	3X5	4 1/4	5	0.73
	AP-405648	U-BOLT, 4.5 X 1.25 X 1/2-13	N/A	4 1/2	1 1/4	0.55
	AP-505265	U-BOLT, 5 X 3.5 X 1/2-13	3.5X3.5	5	3 1/2	0.73
	AP-505125	U-BOLT, 5.25 X 4 X 1/2-13	4X4	5 1/4	4	0.74
	AP-505123	U-BOLT, 5.25 X 6 X 1/2-13	4X6	5 1/4	6	0.84
	AP-505120	U-BOLT, 6.5 X 5 X 1/2-13	5X5	6 1/2	5	0.90
	AP-505122	U-BOLT, 7.25 X 4 X 1/2-13	6X4	7 1/4	4	0.92
	AP-505121	U-BOLT, 7.5 X 6 X 1/2-13	6X6	7 1/2	6	1.05
	AP-515753	U-BOLT, 8.25 X 5 X 1/2-13	7X5	8 1/4	5	1.13
AP-515755	U-BOLT, 8.25 X 7 X 1/2-13	7X7	8 1/4	7	1.27	
5/8"	AP-505545	U-BOLT, 3.5 X 2.0625 X 5/8-11	2X2	3 1/2	2	0.70
	AP-505546	U-BOLT, 4 X 2.5 X 5/8-11	2.5X2.5	4	2 1/2	0.90
	AP-505174	U-BOLT, 4.25 X 3 X 5/8-11	3X3	4 1/2	3	0.95
	AP-500522	U-BOLT, 4.5 X 4 X 5/8-11	3X4	4 1/2	4	1.00
	AP-505130	U-BOLT, 5.5 X 2 X 5/8-11	4X2	5 1/2	2	1.00
	AP-500529	U-BOLT, 5.5 X 4 X 5/8-11	4X4	5 1/2	4	1.10
	AP-505529	U-BOLT, 5.5 X 6 X 5/8-11	4X6	5 1/2	6	1.35
	AP-500539	U-BOLT, 6.5 X 5 X 5/8-11	5X5	6 1/2	5	1.40
	AP-500537	U-BOLT, 6.5 X 7 X 5/8-11	5X7	6 1/2	7	1.52
	AP-500542	U-BOLT, 7.5 X 2 X 5/8-11	6X2	7 1/2	2	1.30
	AP-505530	U-BOLT, 7.5 X 4 X 5/8-11	6X4	7 1/2	4	1.55
	AP-505018	U-BOLT, 7.5 X 6 X 5/8-11	6X6	7 1/2	6	1.60
	AP-500550	U-BOLT, 8.125 X 2 X 5/8-11	7X2	8 1/8	2	1.40
	AP-500554	U-BOLT, 8.5 X 3 X 5/8-11	7X3	8 1/2	3	1.52
	AP-500551	U-BOLT, 8.125 X 4 X 5/8-11	7X4	8 1/8	4	1.55
	AP-505025	U-BOLT, 8.5 X 5 X 5/8-11	7X5	8 1/2	5	1.65
	AP-500538	U-BOLT, 8.5 X 7 X 5/8-11	7X7	8 1/2	7	1.75
	AP-505533	U-BOLT, 10 X 4 X 5/8-11	N/A	10	4	1.75
	AP-505131	U-BOLT, 10 X 5 X 5/8-11	N/A	10	5	1.85
	AP-500578	U-BOLT, 14 X 8 X 5/8-11	8X8	14	8	2.57
AP-500579	U-BOLT, 17 X 8 X 5/8-11	8X8	17	8	3.12	

SIZE	PART NUMBER	DESCRIPTION, VERT X WIDTH X THREADS	TOOLBAR	LEG LENGTH	WIDTH	WEIGHT
3/4"	AP-500543	U-BOLT, 3.5 X 2 X 3/4-10	2X2	3 1/2	2	1.17
	AP-505336	U-BOLT, 4 X 2 X 3/4-10	3X2	4	2	1.30
	AP-500546	U-BOLT, 4.25 X 3 X 3/4-10	3X3	4 1/4	3	1.50
	AP-500528	U-BOLT, 4.375 X 5 X 3/4-10	3X5	4 3/8	5	1.79
	AP-505133	U-BOLT, 4.75 X 5 X 3/4-10	3X5	4 3/4	5	1.89
	AP-500545	U-BOLT, DIAMOND, 5 X 3.375 X 3/4-10	2.25X2.25	5	3 3/8	1.74
	AP-500548	U-BOLT, 5 X 3.5 X 3/4-10	3.5X3.5	5	3 1/2	1.76
	AP-500531	U-BOLT, 5.5 X 4 X 3/4-10	4X4	5 1/2	4	1.95
	AP-505532	U-BOLT, 5.5 X 6 X 3/4-10	4X6	5 1/2	6	2.21
	AP-505531	U-BOLT, 5.5 X 7 X 3/4-10	4X7	5 1/2	7	2.34
	AP-505333	U-BOLT, 5.25 X 2 X 3/4-10	4X2	6	2	1.63
	AP-510750	U-BOLT, DIAMOND, 6 X 5.375 X 3/4-10	4X4	6	5 3/8	2.26
	AP-505538	U-BOLT, 6.5 X 3 X 3/4-10	5X3	6 1/2	3	2.42
	AP-505280	U-BOLT, 6.25 X 4.75 X 3/4-10	N/A	6 1/4	4 3/4	2.24
	AP-505126	U-BOLT, 6.5 X 5 X 3/4-10	5X5	6 1/2	5	2.34
	AP-500535	U-BOLT, 6.5 X 7 X 3/4-10	5X7	6 1/2	7	2.60
	AP-500534	U-BOLT, 7.5 X 2 X 3/4-10	6X2	7 1/2	2	2.21
	AP-500532	U-BOLT, 7.5 X 4 X 3/4-10	6X4	7 1/2	4	2.47
	AP-500533	U-BOLT, 7.75 X 6 X 3/4-10	6X6	7 3/4	6	2.80
	AP-510751	U-BOLT, DIAMOND, 8.125 X 7.375 X 3/4-10	7X4	8 1/8	7 3/8	3.07
	AP-510756	U-BOLT, 8.5 X 4.0625 X 3/4-10	7X4	8 1/2	4	2.73
	AP-505128	U-BOLT, 8.5 X 5 X 3/4-10	7X5	8 1/2	5	2.86
	AP-510755	U-BOLT, 8.5 X 7 X 3/4 3/4-10	7X7	8 1/2	7	3.12
	AP-510752	U-BOLT, DIAMOND, 9.625 X 8.3125 X 3/4-10	7X7	9 5/8	8 5/16	3.25
	AP-515780	U-BOLT, 9 X 5 X 3/4-10	N/A	9	5	2.99
	AP-505543	U-BOLT, 9 X 7 X 3/4-10	N/A	9	7	3.25
AP-505134	U-BOLT, 10 X 5 X 3/4-10	N/A	10	5	3.25	
7/8"	AP-500544	U-BOLT, 5.5 X 4 X 7/8-9	4X4	5 1/2	4	2.65
	AP-510757	U-BOLT, 5.75 X 4.0625 X 7/8-9	4X4	5 3/4	4	2.74
	AP-505542	U-BOLT, 8.5 X 6.125 X 7/8-14, FINE THREAD	7X6	8 1/2	6 1/8	4.09
	AP-505132	U-BOLT, 9 X 7 X 7/8-9	7X7	9	7	4.27
1"	AP-505135	U-BOLT, 9 X 7 X 1-8	7X7	9	7	5.63

**USE THE U-BOLT IDENTIFICATION GUIDE BELOW TO PROPERLY SIZE YOUR U-BOLT**

Radius per tooling requirements OR SPECIFY

ALL SHIELDAG U-BOLTS ARE MADE IN USA & FURNISHED WITH NUTS & LOCKWASHERS

THREADS

H

W

TL

**Please identify your U-bolt so that we can give you a quote!**

**H = Height or "Leg Length"** \_\_\_\_\_

**W = Inside width** \_\_\_\_\_

**THREADS =** \_\_\_\_\_  
**examples:** 3/4" course, 1/2" fine

**TL = Thread Length** \_\_\_\_\_

**Plating required?** \_\_\_\_\_  
**Note: U-bolts are plated with EITHER bright zinc or yellow zinc unless specified**

<p><b>SHIELD</b>          SHIELDAG COMPANY</p>				<p>DATE: 01-15-15</p>			
<p><b>U-BOLT IDENTIFICATION CHART</b></p>				<p>Per ASME, ASAE specifications</p>			
<p><b>U-BOLTS</b></p>				<p>REV. NO.</p>			



**Making Milo Harvest FUN Again!**

**ARRO**®  
 Alternate Rotary Rowcrop Option

**Corn Head Conversions to Harvest Sorghum, Sunflowers and Millet**

1-ROW Kit Number

CONVERSION FOR

KK-882159	Deere 40 & 90-Series
KK-882118	Deere 600C early 8-tooth
KK-882076	Deere 600C late 6-tooth
KK-882365	Caselh 3200-3400-series
KK-882365	Caselh 22-2400-series
KK-882365	New Holland 96-98-99C
KK-883165	Caselh 1083
KK-883264	Caselh 4400-series
KK-882670	AGCO Gleaner Hugger
KK-883249	Claas 8-30, 12-30, 16-30



Distributed by ShieldAg Equipment, Hutchinson, KS shieldag.com 800-798-1968

ARRO® is protected under US Patent number 10,123,480 by Kopper Kutter, LLC, Cimarron, KS

# DON'T LOSE YOUR MILO ON THE GROUND THIS YEAR!!

## Milo Guards and Crop Savers



Milo Guards & Crop Savers pay for themselves in LESS than 80 acres!!!

### QUALITY CONSTRUCTION:

- High-Strength Steel • Precision Fabrication • Heat-Treated Tine Wires
- Flex and Draper Headers Available • Various Sizes Offered • Powder Coat Paint • Easy Installation • Guaranteed Fit • Made in USA!



Designed for  
ALL Grain  
Headers by  
MacDon, Deere,  
CaseIH & others

SAVE  
YOUR  
MILO!

[WWW.SHIELDAG.COM](http://WWW.SHIELDAG.COM)

(800) 798-1968<sup>®</sup>

JOHN DEERE 200- and 900-series headers with 3" guard point spacing							8/22/2023	Optional	Retail Price	Total Kit
Set #	Cut size (Width ft)	# of FG-087 8-points	# of FG-077 7-points	# of Clips	# of Clasps	Wt. Lbs.	Header Kit Retail Price	Grain Saver Boots Quantity Required	For set of GS-boots	Price including GS-Boots
FG-537	14	4	3	14	14	40	\$678.08	26	\$230.88	\$908.96
FG-577	15	1	7	16	16	43	\$746.27	28	\$248.64	\$994.91
FG-617	16	5	3	16	16	46	\$778.39	30	\$266.40	\$1,044.79
FG-697	18	6	3	18	18	51	\$878.70	34	\$301.92	\$1,180.62
FG-737	19	3	7	20	20	54	\$946.89	36	\$319.68	\$1,266.57
FG-777	20	7	3	20	20	58	\$979.01	38	\$337.44	\$1,316.45
FG-857	22	8	3	22	22	63	\$1,079.32	42	\$372.96	\$1,452.28
FG-937	24	9	3	22	22	68	\$1,167.71	46	\$408.48	\$1,576.19
FG-997	25	8	5	26	26	75	\$1,263.88	49	\$435.12	\$1,699.00
FG-1177	30	5	11	32	32	86	\$1,516.63	58	\$515.04	\$2,031.67

Guard Part #	Clasp	Clip	Guard Part #	Clasp	Clip
H-61954	C-2	H-3	H-113571	C	H-3
H-75386	C	H-3	H-145791	C	H-3
H153855 or H25603	C	H-3	H-153719	C-2	H-3
Other	C	H			

↑  
**One ABM-2005 Grain Saver Boot On every OTHER Tyne OPTIONAL**

JOHN DEERE Draper Headers, 600- and 900-series RIGID DRAPERS and 600-series Rigid Auger, guards on 4" spacing							Optional	Retail Price	Total Kit	
Set #	Cut size (Width ft)	# of ABM-D-6 6-points	# of Clips	# of Clasps	Wt. Lbs.	Header Kit Retail Price	Grain Saver Boots Quantity Required	For set of GS-boots	Price including GS-Boots	
FG-925D	25	12	SEE NOTE	24	24	53	\$1,041.48	72	\$639.36	\$1,680.84
FG-930D / FG-090D	30	15		30	30	66	\$1,301.85	90	\$799.20	\$2,101.05
FG-635R/D	35	17	SEE NOTE	34	34	73	\$1,475.43	102	\$905.76	\$2,381.19
FG-936D	36	18		36	36	79	\$1,562.22	108	\$959.04	\$2,521.26

NOTE: 25' and 35' drapers use 12ea or 17ea 6-point milo guards and leave 6" of each end of header without milo guards

Guard Part #	Clasp	Clip	Part #	Clasp	Clip
H-213405	JDF-010	ABM-D-1J	H-229539	JDF-010	ABM-D-1J
H213508	JDF-010	ABM-D-1J			

↑  
**One ABM-2005 Grain Saver Boot On EVERY Tyne RECOMMENDED**

JOHN DEERE Flex Headers, 600- and 900-series FLEX, BOLT-ON guard system, guards on 4" spacing							8/22/2023	Optional	Retail Price	Total Kit
Set #	Cut size (Width ft)	# of ABM-D-3F 3-points	New Bolts Required	One of ea LH & RH finger	Deere Bolt #	Wt. Lbs.	Header Kit Retail Price	Grain Saver Boots Quantity Required	For set of GS-boots	Price including GS-Boots
FG-060 / 620F	20	19	40	2	03M7196	65	\$1,590.00	59	\$523.92	\$2,113.92
FG-066 / 622F	22	21	44	2	03M7196	72	\$1,750.72	65	\$577.20	\$2,327.92
FG-075 / 625F	25	24	48	2	03M7196	82	\$1,991.80	74	\$657.12	\$2,648.92
FG-090 / 630F	30	29	58	2	03M7196	99	\$2,393.60	89	\$790.32	\$3,183.92
FG-105 / 635F	35	34	70	2	03M7196	116	\$2,795.40	104	\$923.52	\$3,718.92
FG-120 / 640F	40	39	80	2	03M7196	133	\$3,197.20	119	\$1,056.72	\$4,253.92

This is a bolt-on 3-point system, purchase bolts from Shield or your dealer, Shield ABM-3M7196 retail \$1.25ea  
 NEW FOR 2016, Kits will include 1ea Left hand Single finger ABM-D-3FL

and 1ea Right hand Single finger ABM-D-3FR

Guard Part #	Guard Description
H213398	Guard with (2) LONG points and (1) SHORT point
H205992	Guard with (2) LONG points and (1) SHORT point
H205448	Guard with (2) LONG points and (1) SHORT point
H229537	Heat-treated Guard with (2) LONG points and (1) SHORT point
H213507	Guard with (1) LONG point and (2) SHORT points
AH213055	Guard with (1) LONG point and (2) SHORT points
H229538	Heat-treated guard with (1) LONG point and (2) SHORT points

↑  
**One ABM-2005 Grain Saver Boot On EVERY Tyne OPTIONAL**

shieldag.com 800-798-1968

**CASE IH / INT. HARVESTER, guards on 3" spacing**

Set #	Cut size (Width ft)	# of FG-087 8-points	# of FG-077 7-points	# of Clips	# of Clasps	Wt. Lbs.	8/22/2023 Header Kit Retail Price	Optional Grain Saver Boots Quantity Required	Retail Price For set of GS-boots	Total Kit Price including GS-Boots
FG-717	18	8	1	18	18	53	\$894.76	35	\$310.80	\$1,205.56
FG-797	20	9	1	20	20	58	\$995.07	39	\$346.32	\$1,341.39
FG-877	22	10	1	22	22	68	\$1,095.38	43	\$381.84	\$1,477.22
FG-937	24	9	3	24	24	68	\$1,179.63	46	\$408.48	\$1,588.11
FG-1007	25	9	4	26	26	73	\$1,271.91	50	\$444.00	\$1,715.91
FG-1207	30	15	0	30	30	88	\$1,504.65	60	\$532.80	\$2,037.45
FG-118D	30	6	10	32	32	88	\$1,524.66	59	\$523.92	\$2,048.58
FG-1407	35	0	20	40	40	103	\$1,845.60	70	\$621.60	\$2,467.20
FG-1407 **	36	0	20	40	40	103	\$1,845.60	70	\$621.60	\$2,467.20
FG-136FD	36	17	0	34	34	103	\$1,705.27	68	\$603.84	\$2,309.11
FG-170FD	40	16	6	44	44	114	\$2,158.64	85	\$754.80	\$2,913.44
FG-186FD	45	18	6	48	48	128	\$2,359.26	93	\$825.84	\$3,185.10

\*\* Alternate for RIGID Draper, leaving one guard point exposed

FD headers are Flex-drapers made by MacDon for CNH and New Holland

40' and 45' Flex-drapers use 6ea 7 point Milo-guards in center of header

For All Flex-drapers, cover center of header first, then work out from the main flex joints to cover outboard guards

Guard Part #	Clasp	Clip	Guard Part #	See NOTE: Clasp	Clip
633089	C-2	H-2	118344	C-2 or C	H-4
633240R1	C-2	H-3	87702973	C-2 or C	H-4
1307299	C-2	H-4	118301	C-2 or C	H-4
OTHER	C	H	87442324	C-2 or C	H-4

Use C-2 Clasp for 7/16" or 12mm bolt

Use C-Clasp for 3/8" or 8mm bolt

↑  
One ABM-2005  
Grain Saver Boot  
On every OTHER Tyne  
OPTIONAL

Call ABM and we will walk you through what you need for new-style draper and flex-draper platforms !!  
800-798-1968

**NEW HOLLAND / FORD, guards on 3" spacing**

Set #	Cut size (Width ft)	# of FG-087 8-points	# of FG-077 7-points	# of Clips	# of Clasps	Wt. Lbs.	8/22/2023 Header Kit Retail Price	Optional Grain Saver Boots Quantity Required	Retail Price For set of GS-boots	Total Kit Price including GS-Boots
FG-697	18	6	3	18	18	51	\$878.70	34	\$301.92	\$1,180.62
FG-797	20	9	1	20	20	58	\$995.07	39	\$346.32	\$1,341.39
FG-877	22	10	1	22	22	68	\$1,095.38	43	\$381.84	\$1,477.22
FG-937	24	9	3	24	24	79	\$1,179.63	46	\$408.48	\$1,588.11
FG-977	25	6	7	26	26	69	\$1,247.82	48	\$426.24	\$1,674.06
FG-1167	30	11	4	30	30	85	\$1,472.53	58	\$515.04	\$1,987.57
FG-118D	30	6	10	32	32	88	\$1,524.66	59	\$523.92	\$2,048.58
FG-1407	35	0	20	40	40	103	\$1,845.60	70	\$621.60	\$2,467.20
FG-1407 **	36	0	20	40	40	103	\$1,845.60	70	\$621.60	\$2,467.20
FG-136FD	36	17	0	34	34	103	\$1,705.27	68	\$603.84	\$2,309.11
FG-170FD	40	16	6	44	44	114	\$2,158.64	85	\$754.80	\$2,913.44
FG-186FD	45	18	6	48	48	128	\$2,359.26	93	\$825.84	\$3,185.10

\*\* Alternate for RIGID Draper, leaving one guard point exposed

FD headers are Flex-drapers made by MacDon for CNH and New Holland

40' and 45' Flex-drapers use 6ea 7 point Milo-guards in center of header

For All Flex-drapers, cover center of header first, then work out from the main flex joints to cover outboard guards

Guard Part #	Clasp	Clip	Guard Part #	See NOTE: Clasp	Clip
65327	C-2	H-3	118344	C-2 or C	H-4
695501	C-2	H-4	87702973	C-2 or C	H-4
8652187	C-2	H-4	118301	C-2 or C	H-4
858778	C-2	H-4	87442324	C-2 or C	H-4
134024	C	H-3	86615982	C-2	H-4

Use C-2 Clasp for 7/16" or 12mm bolt

Use C-Clasp for 3/8" or 8mm bolt

↑  
One ABM-2005  
Grain Saver Boot  
On every OTHER Tyne  
OPTIONAL

Call ABM and we will walk you through what you need for new-style draper and flex-draper platforms !!  
800-798-1968



**MASSEY FERGUSON/MASSEY HARRIS, guards on 3" centers**

Set #	Cut size (Width ft)	# of FG-087 8-points	# of FG-077 7-points	# of Clips	# of Clasps	Wt. Lbs.	8/22/2023 Header Kit Retail Price	Optional Grain Saver Boots Quantity Required	Retail Price For set of GS-boots	Total Kit Price including GS-Boots
FG-507	13	1	6	14	14	38	\$653.99	25	\$222.00	\$875.99
FG-547	14	5	2	14	14	41	\$686.11	27	\$239.76	\$925.87
FG-587	15	2	6	16	16	44	\$754.30	29	\$257.52	\$1,011.82
FG-627	16	6	2	16	16	45	\$786.42	31	\$275.28	\$1,061.70
FG-707	18	7	2	18	18	52	\$886.73	35	\$310.80	\$1,197.53
FG-787	20	8	2	20	20	58	\$987.04	39	\$346.32	\$1,333.36
FG-947	24	10	2	24	24	69	\$1,187.66	47	\$417.36	\$1,605.02
FG-1167	30	11	4	30	30	86	\$1,472.53	58	\$515.04	\$1,987.57
FG-1407 35' draper	35	0	20	35	35	103	\$1,815.80	70	\$621.60	\$2,437.40

35' Massey 9250 Draper uses JDF-10 C-Clasp and WND-004 H-3 Clip, Same as Gleaner Model 9250

Guard Part #	Clasp	Clip	Guard Part #	Clasp	Clip
BC258AC	C	H-3	OTHER	C	H
BC240AC	C	H-3			

↑  
One ABM-2005  
Grain Saver Boot  
On every OTHER Tyne  
OPTIONAL

**GLEANER/DUETZ/ALLIS CHALMERS, guards on 3" spacing**

Set #	Cut size (Width ft)	# of FG-087 8-points	# of FG-077 7-points	# of Clips	# of Clasps	Wt. Lbs.	8/22/2023 Header Kit Retail Price	Optional Grain Saver Boots Quantity Required	Retail Price For set of GS-boots	Total Kit Price including GS-Boots
FG-667	17	3	6	18	18	49	\$854.61	33	\$293.04	\$1,147.65
FG-707	18	7	2	18	18	52	\$886.73	35	\$310.80	\$1,197.53
FG-747	19	4	6	20	20	55	\$954.92	37	\$328.56	\$1,283.48
FG-787	20	8	2	20	20	58	\$987.04	39	\$346.32	\$1,333.36
FG-867	22	9	2	22	22	63	\$1,087.35	43	\$381.84	\$1,469.19
FG-907	23	6	6	24	24	66	\$1,155.54	45	\$399.60	\$1,555.14
FG-947	24	10	2	24	24	69	\$1,187.66	47	\$417.36	\$1,605.02
FG-955	25	9	4	26	26	72	\$1,271.91	50	\$444.00	\$1,715.91
FG-1127	27	0	16	32	32	81	\$1,476.48	56	\$497.28	\$1,973.76
FG-1207	30	15	0	30	30	88	\$1,504.65	60	\$532.80	\$2,037.45
FG-1407 35' draper	35	0	20	35	35	103	\$1,815.80	70	\$621.60	\$2,437.40

35' Gleaner Draper uses JDF-10 C-Clasp and WND-004 H-3 Clip, Gleaner Model 9250

Guard Part #	Clasp	Clip	Guard Part #	Clasp	Clip
71341601	C	H-4	OTHER	C	H
1116504	C	H-3			

↑  
One ABM-2005  
Grain Saver Boot  
On every OTHER Tyne  
OPTIONAL

**Challenger/Lexion, guards on 3" spacing**

Set #	Cut size (Width ft)	# of FG-087 8-points	# of FG-077 7-points	# of Clips	# of Clasps	Wt. Lbs.	8/22/2023 Header Kit Retail Price	Optional Grain Saver Boots Quantity Required	Retail Price For set of GS-boots	Total Kit Price including GS-Boots
FG-1007	25	9	4	26	26	73	\$1,271.91	50	\$444.00	\$1,715.91
FG-1207	30	15	0	30	30	88	\$1,504.65	60	\$532.80	\$2,037.45
FG-1387 / F535	35	5	14	38	38	103	\$1,793.47	69	\$612.72	\$2,406.19
FG-1607	40	13	8	42	42	118	\$2,042.27	80	\$710.40	\$2,752.67

The Lexion F535 uses 38ea WND-004 H-3 Clip and the K11-001 C-2 Clasp

To Select Clips and Clasps for Challenger/Lexion/Claas Combines, please call us with your Guard Part Numbers, Guard Bolt Diameters and any special guard configurations

↑  
One ABM-2005  
Grain Saver Boot  
On every OTHER Tyne  
OPTIONAL

shieldag.com 800-798-1968

**MACDON, guards on 3" guards**

Set #	Cut size (Width ft)	# of FG-087 8-points	# of FG-077 7-points	# of Clips	# of Clasps	Wt. Lbs.	8/22/2023 Header Kit Retail Price	Optional Grain Saver Boots Quantity Required	Retail Price For set of GS-boots	Total Kit Price including GS-Boots
FG-1207	30	15	0	30	30	86	\$1,504.65	60	\$532.80	\$2,037.45
FG-1407	35	0	20	40	40	103	\$1,845.60	70	\$621.60	\$2,467.20
FG-1447	36	18	0	36	36	102	\$1,805.58	72	\$639.36	\$2,444.94
FG-136FD	36	17	0	34	34	103	\$1,705.27	68	\$603.84	\$2,309.11
FG-170FD	40	16	6	44	44	114	\$2,158.64	85	\$754.80	\$2,913.44
FG-186FD	45	18	6	48	48	128	\$2,359.26	93	\$825.84	\$3,185.10

FD headers are Flex-drapers also made for CNH and New Holland  
 40' and 45' Flex-drapers use 6ea 7 point Milo-guards in center of header  
 For All Flex-drapers, cover center of header first, then work out from the main flex joints to cover outboard guards

Guard	Clasp	Clip	Guard	Clasp	Clip
23064	C-2	H-4	118344	C-2 or C	H-4
26370	C-2	H-4	87702973	C-2 or C	H-4
118345	C-2	H-4	118301	C-2 or C	H-4
OTHER	C-2	H-4	87442324	C-2 or C	H-4

Use C-2 Clasp for 7/16" or 12mm bolt      Use C-Clasp for 3/8" or 8mm bolt

↑  
**One ABM-2005  
 Grain Saver Boot  
 On every OTHER Tyne  
 OPTIONAL**

NOTE: Some MacDon setups use CaseIH draper guards  
 Call us with a guard part number and we can help you with the proper system  
 Call ABM and we will walk you through what you need  
 for new-style draper and flex-draper platforms !!  
 800-798-1968

**WHITE, guards on 3" centers**

Set #	Cut size (Width ft)	# of FG-087 8-points	# of FG-077 7-points	# of Clips	# of Clasps	Wt. Lbs.	8/22/2023 Header Kit Retail Price	Optional Grain Saver Boots Quantity Required	Retail Price For set of GS-boots	Total Kit Price including GS-Boots
FG-437	11	1	5	12	12	44	\$561.71	21	\$186.48	\$748.19
FG-517	13	2	5	14	14	39	\$662.02	25	\$222.00	\$884.02
FG-597	15	3	5	16	16	44	\$762.33	29	\$257.52	\$1,019.85
FG-717	18	1	8	18	18	53	\$838.55	32	\$284.16	\$1,122.71
FG-797	20	9	1	20	20	58	\$995.07	39	\$346.32	\$1,341.39
FG-877	22	10	1	22	22	68	\$1,095.38	43	\$381.84	\$1,477.22
FG-957	24	11	1	24	24	70	\$1,195.69	47	\$417.36	\$1,613.05

Guard	Clasp	Clip	Guard	Clasp	Clip
9510220	C	H-3	31-1713400	NO FIT	
FC68-2	C	H	OTHER	C	H

**One ABM-2005  
 Grain Saver Boot  
 On every OTHER Tyne  
 OPTIONAL**

PART #	ABM Replacement Parts	08/22 Retail
FG-087	8 POINT SECTION	\$88.39
FG-077	7 POINT SECTION	\$80.36
ABM-D-6	6 POINT SECTION	\$72.29
ABM-D-3F	3-PT Bolt-on guard	\$80.36
ABM-D-3FL	Left finger w/ tyne wire	\$31.58
ABM-D-3FR	Right finger w/ tyne wire	\$31.58
ABM-3M7196	M10-1.5 X 50mm carr. bolt	\$1.61
JDF-010	C-CLASP	\$2.93
K11-001	C-2 CLASP	\$2.93
WND-002	H-CLIP	\$3.03
WND-004	H-3 CLIP	\$3.03
WND-103	H-4 CLIP	\$3.03
WND-105	H-5 CLIP	\$3.03
ABM-D-1	DRAPER CLIP	\$4.32
ABM-D-1J	JOHN DEERE DRAPER CLIP	\$4.32
11X-1308	Z-CLIP	\$4.32
11G-1301	TINE CLIP	\$1.14
11G-1401	GUARD POINT CLIP	\$1.42
11X-3202	TINE WIRE	\$2.83
11X-3202F	EXTRA LONG TINE WIRE	\$5.20
ABM-2005	GRAIN SAVER BOOT	\$8.88
FLX-HC-3	HOG RING	\$0.26

All of the Set #'s listed above have been proven to work  
 on the brands and header widths shown  
 Because Guard Part Numbers and OE-Guard Suppliers change frequently,  
 We recommend that you help your dealer specify a correct set of Milo-Guards for your machine  
 Please have this information when you contact your dealer  
 Guard part number or part numbers used on your machine  
 Model Number and cutting width  
 Main guard point spacing (usually either 3" or 4")  
 Guard bolt diameter, usually either 3/8", 7/16" or 10mm diameter  
 Brand Name--some headers are "private labeled" for major OE Brands  
 We will assist you in the selection of a full set of milo-guards or replacement  
 parts as needed so that you can get back in the field and start saving grain !!  
**WARRANTY:** ABM will replace any part it manufactures that proves to be defective  
 for a period of one year from the date of purchase. ABM is not responsible for  
 damages cause by improper installation or misuse of its products nor is ABM responsible  
 for any consequential damages to combines or headers.

[shieldag.com](http://shieldag.com)  
 800-798-1968

Schumacher EasyCut does not make headers. They make a world-class cutting system retrofittable to most modern combines. Therefore, ABM recommends that your farmer/customer goes back to the original fitup method for Milo Guards. COUNT the number of exposed guard points. Charts show options for header widths based on the number of exposed guard points. When cutting Sorghum (Milo), we recommend that Flex headers are "locked out" in the rigid position.

**All OEM Headers equipped with Schumacher EasyCut SCH guard and sickle cutting systems**

8/22/2023

Set #	Cut size (Width ft)	# of FG-087 8-points	# of FG-077 7-points	# of H-5 Clips P/N WND-105	# of C-Clasps P/N JDF-010	Wt. Lbs.	Retail Price w/o GS boots	Grain Saver Boots Required	Retail Price GS-boots	Total Kit Price including GS-Boots
SCH-917-79	20	9	1	20	20	60	\$995.07	39	\$346.32	\$1,341.39
SCH-657-83	21	6	5	22	22	64	\$1,063.26	41	\$364.08	\$1,427.34
SCH-837-85	22	8	3	22	22	68	\$1,079.32	42	\$372.96	\$1,452.28
SCH-937-93	24	9	3	24	24	74	\$1,179.63	46	\$408.48	\$1,588.11
SCH-947-100	25	9	4	26	26	78	\$1,271.91	50	\$444.00	\$1,715.91
SCH-1147-116	30	11	4	30	30	88	\$1,472.53	58	\$515.04	\$1,987.57
SCH-5117-117	30	5	11	32	32	88	\$1,516.63	58	\$515.04	\$2,031.67
SCH-1507-120	30	15	0	30	30	88	\$1,504.65	60	\$532.80	\$2,037.45
SCH-1707-136	36	17	0	34	34	103	\$1,705.27	68	\$603.84	\$2,309.11
SCH-0207-140	36	0	20	40	40	103	\$1,845.60	70	\$621.60	\$2,467.20
SCH-1667-170	40	16	6	44	44	119	\$2,158.64	85	\$754.80	\$2,913.44
SCH-1767-178	42	17	6	46	46	127	\$2,258.95	89	\$790.32	\$3,049.27
SCH-1867-186	45	18	6	48	48	139	\$2,359.26	93	\$825.84	\$3,185.10

Part Number KEY: SCH-917 = 20' platform using 9ea 8-points and 1ea 7-point, -79 = 79 exposed guard points  
 For retrofitting ABM Milo Guards to any OEM header equipped with Schumacher EasyCut, please COUNT the number of exposed guard points, use the charts to determine the correct SET # and quantities of 8-points and 7-points required to fill out the header  
 For all Flex headers, work from the center out, avoiding placement of rigid milo guard bars over the flex joints in the header

↑  
**One ABM-2005 Grain Saver Boot**  
**On every OTHER Tyne**

**ALWAYS INCLUDE GRAIN SAVER BOOTS**  
**For Optimum Performance**

Guard	JDF-010	WND-105	Guard	JDF-010	WND-105
Part #	C-Clasp	H-5 Clip	Part #	C-Clasp	H-5 Clip
16538 BLACK	C	H-5	16539 RED	C	H-5
16540 GREY	C	H-5	Use C-Clasp for 3/8", 8mm or 10mm bolt		

←--ALL EasyCut Guard systems use the SAME ABM Milo Guard setup

For every C-Clasp installed, replace one 10mm Carriage bolt with a 3/8" or 10mm Hex bolt of the same length, install with NUT UP

**HoneyBee Headers with EITHER 87112 or 87113 HoneyBee Guards, typically used on AirFlex headers**

**HoneyBee Grain Belt and 4000-series headers use complete Schumacher EasyCut SCH guards and sickles, use the SCH-charts above**

Set #	Cut size (Width ft)	# of FG-087 8-points	# of FG-077 7-points	# of H-5 Clips P/N WND-105	# of C-2 Clasps P/N K11-001	Wt. Lbs.	Retail Price w/o GS boots	Grain Saver Boots Required	Retail Price GS-boots	Total Kit Price including GS-Boots
HB-230AF-122	30	10	6	32	32	88	\$1,556.78	61	\$541.68	\$2,098.46
HB-236AF-146	36	6	14	40	40	103	\$1,893.78	73	\$648.24	\$2,542.02
HB-240AF-162	40	15	6	42	42	119	\$2,058.33	81	\$719.28	\$2,777.61
HB-245AF-182	45	14	10	48	48	139	\$2,327.14	91	\$808.08	\$3,135.22
HB-250AF-202	50	20	6	52	52	148	\$2,559.88	101	\$896.88	\$3,456.76

Part Number KEY: HB-230AF = HoneyBee 30 foot Air Flex, -122 = 122 exposed guard points  
 For all Flex headers, work from the center out, avoiding placement of rigid milo guard bars over the flex joints in the header

↑  
**One ABM-2005 Grain Saver Boot**  
**On every OTHER Tyne**

**ALWAYS INCLUDE GRAIN SAVER BOOTS**  
**For Optimum Performance**

Guard	K11-001	WND-105	Guard	K11-001	WND-105
Part #	C-2 Clasp	H-5 Clip	Part #	C-2 Clasp	H-5 Clip
87112	C-2	H-5	87113	C-2	H-5
Use C-2 Clasp for 7/16" or 12mm bolt					

For every C-2 Clasp installed, replace one 7/16" Carriage bolt with a 7/16" Hex bolt of the same length, install with NUT UP

Schumacher EasyCut Header system



**ALWAYS SELL SYSTEMS WITH ABM-2005 Grain Saver Boots on every OTHER point !!**

shieldag.com 800-798-1968



HoneyBee AirFlex Header system

**ALWAYS SELL SYSTEMS WITH ABM-2005 Grain Saver Boots on every OTHER point !!**

8/1/2023

# Shield Ag Cropsaver Staggered Designs for Milo

The new staggered design for guards on 3" centers will still be in 3' lengths. For example, a 30' header will take 10 units. The new 3" cutting system will have 4 tabs instead of the normal 3, and 12 fingers instead of 6. This unit should fit any combine on the market with guards on 3" centers. There will be only two models, one for the 3" guard and one for the 4" guard. This should cover virtually all current guards. All will use the "Rock Guard Support Bar". These will be laser cut into the support bar, which will make it always fit.

## Guards on 3" Centers:

Part #	Description
SACS-SPL	Short Plastic Part
SACS-LPL	Long Plastic Part
SACS-3S	Complete Unit

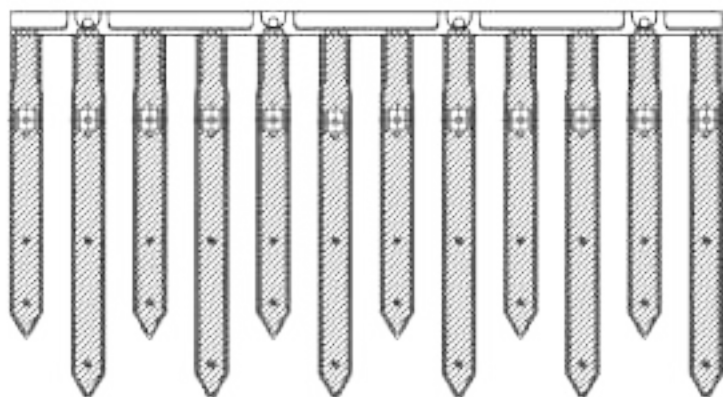

SACS-3S

### PARTS REQUIRED:

- 1 Ea. SACS-3ADJ - WELDMENT
- 6 Ea. SACS-SPL - SHORT PLASTIC
- 6 Ea. SACS-LPL - LONG PLASTIC
- 24 Ea. ZK1-1 (1/4 x 1 GR. 5 CARRIAGE BOLT)
- 24 Ea. LN1 (1/4 NYLOCK HEX NUT)

Cutting systems using the staggered finger design on 4" cutting systems (Draper and Flex) will use the same section, this section will be 2' in length. For example, 15 units are required to cover a 30' head, 18 units for a 35' or 36' head. These sections will have 3 tabs on the back, and 6 fingers. These units will also be using the "Rock Guard Support Bar".

## Guards on 4" Centers:

Part #	Description
SACS-SPL	Short Plastic Part
SACS-LPL	Long Plastic Part
SACS-4S	Complete Unit

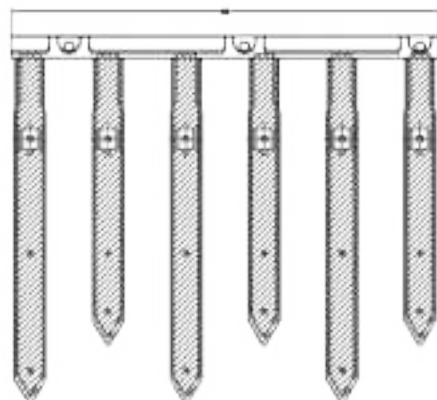

SACS-4S

### PARTS REQUIRED:

- 1 Ea. SACS-4ADJ - WELDMENT
- 3 Ea. SACS-SPL - SHORT PLASTIC
- 3 Ea. SACS-LPL - LONG PLASTIC
- 12 Ea. ZK1-1 (1/4 x 1 GR. 5 CARRIAGE BOLT)
- 12 Ea. LN1 (1/4 NYLOCK HEX NUT)



# Original ShieldAg/Britten Crop Savers

## STILL AVAILABLE

ShieldAg/Britten Crop Savers are manufactured in Kansas under U.S. Patent #5,105,610 and are designed for most popular makes and models of standard small grain headers, All Crop Savers come in 3' sections and have no moving parts. Plastic fingers are UHMW plastic with Sunlight Protection added.



### Milo & Sunflower Crop Savers for standard small grain header with guard points on 3" centers

Part #	Description	Weight Lbs
MCS-PL	Replacement UHMW Plastic Milo Crop Saver Fingers <i>Purchase 6 fingers for each 3' section</i>	1.0
MCS-1D	3' Milo Crop Saver Assembly, includes fingers & finger hardware	33.0

### Replacement hardware for new plastic finger installation

Part #	Description	Weight Lbs
ZK1-1	1/4" x 1" Crop Saver Finger Bolt, two bolts required per finger	0.09
LN1	1/4" Nylock Crop Saver Finger Nut, two nuts required per finger	0.07



PO Box 687 • Hutchinson, KS 67504-0687 • Fax (620)662-7482



# SHIELDAG Conveyors

By Universal Industries, Inc.

**The highest standard capacity belt conveyors  
made—from the name you've come to trust  
for innovative agricultural equipment**

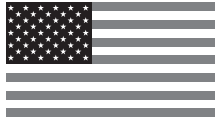

**Made In USA**



- **22-Series Conveyors**
- **15-Series Conveyors**
- **Drive-Over "Truck Stop"**
- **Low Profile Transfer**
- **Custom Applications**

**ShieldAg offers a complete line of belt conveyors  
for every application**



**1-800-798-1968 • Fax 1-620-662-7482  
www.shieldagconveyors.com • www.shieldag.com**

Contact us at  
**1-800-798-1968**  
or visit us on the web at  
**www.shieldagconveyors.com**

**SA-ADRIEVOVER "Truck Stop"**

Drive right over it with semi-tractor-trailer or grain cart, no need to "hit ramps" capacity adjustable up to 10,000 BU/hr



**SA-A1515 Low Profile Transfer**

Perfect for unloading belly dumps and on-farm grain/seed handling



**15-Series Conveyors**

Terrific choice for on-farm grain/seed handling. Available up to 85' long with 42' discharge height.



**The "Big Boys"—22-Series Conveyors** The biggest tube, widest belt conveyors in the industry—available up to 95' long with 46' discharge height. If you need high capacity, gentle crop/commodity handling and speed, ShieldAg 22-Series Conveyors fit your needs!

# Round Baler Belting available for most makes and models

Available in Pre-Cut and Pre-Laced sizes, or in bulk

Free shipping for qualifying orders!  
Lacing & Lacing tools are available!

Please specify the following:

Make: \_\_\_\_\_  
Model: \_\_\_\_\_  
Manufacture Year: \_\_\_\_\_

TYPE OF CONSTRUCTION:

2 PLY \_\_\_\_\_  
or  
3 PLY \_\_\_\_\_

CHOOSE TEXTURE:

Smooth Top \_\_\_\_\_  
Mini-Rough Top \_\_\_\_\_  
Rough Top \_\_\_\_\_  
Chevron Top \_\_\_\_\_  
Diamond Top \_\_\_\_\_

CHOOSE LACING:

Flexco Rivet Lacing \_\_\_\_\_  
Clipper Lacing \_\_\_\_\_  
Flexco 125 Staple Lacing \_\_\_\_\_  
2-A Minet Lacing \_\_\_\_\_

CHEVRON TOP



DIAMOND TOP



ROUGH TOP



Call ShieldAg for Bulk Roll Pricing

Please allow ample lead times when ordering belting  
Due to the seasonality, lead times cannot be guaranteed

ShieldAg.com 800-798-1968



Available in TWO  
Handle Lengths to fit  
ANY Gooseneck Trailer!

**EZE LATCH**  
For Trailers



PO Box 356  
Turon, KS 67583  
vernon@ezelatch.com

## The simple solution for gooseneck trailer hook-up



The easy way to hook up any gooseneck trailer from the ground. No more banged heads, busted shins, or belt buckle scrapes on your truck bed!

The EZE-Latch is totally mechanical with only one moving part. It is very durable and trouble-free.

### Eze-Loc Gooseneck trailer lock

Locks through the crank handle cross shaft

For maximum security of your gooseneck trailer

**EZE LATCH**  
For Trailers

1-866-231-8589 or [ezelatch.com](http://ezelatch.com)



**800-798-1968**     **ShieldAg.com**

# CASTPRO / SHIELDAG SUGAR BEET LIFTER WHEELS

## 2 MODELS NOW AVAILABLE!!!

**Our Part Number BW-001** replaces Amity Part Number 300734, Alloway Part Number 700-3-0303 Red River / Wic / Wilrich Part Number 700576

**Our Part Number BW-002** replaces Art's Way Part Numbers 491750, 264670 and 598500

Designed by a lifelong beet wheel re-manufacturing company—these were the design requirements:

- Heat-treated 8630 steel for strength and resistance to rock damage, with stouter spokes
- Cast-in puller-optimizers in the teeth
- Smooth lines and radii to take more rock strikes without breaking
- Machined hub face and bolt-holes for perfect fit and less runout—the PAIR running on the machine will run as a "true pair" and not fight each other
- Fully weldable to accommodate spoke fillers and other customer add-ons
- Both lifter wheels now accommodate bolt-in filler tabs
- Less expensive than the OEM wheels



Shield BW-001 For Amity, Alloway Red River, Wic and Wilrich



Shield BW-002 For Art's Way Lifters



# INNOVATION IN AGRICULTURE STRAIGHT FROM THE HEARTLAND



## DIVISIONS OF SHIELD AGRICULTURAL EQUIPMENT

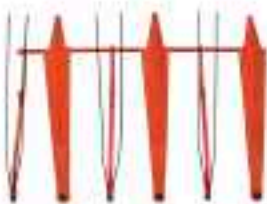

## DISTRIBUTOR FOR

Corn head →  
Row crop conversion



**SHIELDAG.COM • 800-798-1968**



SHIPPING: 950 SCOTT BLVD • SOUTH HUTCHINSON, KS 67505 MAILING: PO BOX 687 • HUTCHINSON, KS 67504

---

**STRAIGHT FROM THE**  
**HEARTLAND**  
**SHIELDAG.COM**



CALL THE DEALER **NEAREST YOU**

**PHONE:** (620) 662-7221 (800) 798-1968

**FAX:** (620) 662-7482

**MAILING:** PO BOX 687 • HUTCHINSON, KS 67504

**SHIPPING:** 950 SCOTT BLVD • SOUTH HUTCHINSON, KS 67505

