

STRAIGHT FROM THE HEARTLAND

2024 - 2025



**CHROME
CATALOG**

800-798-1968
SHIELDAG.COM



Quality Agricultural Equipment

Manufacturers of:

V-Blades • Sweeps • Chisels & Spikes • Disc Blades • Drill Discs & Hoe Drill Points
Related Tillage & Planting Hardware • Fertilizer Knives • Shanks • Coulter Blades • Crop Savers
Precision Planting Equipment • Conservation Ripper Points • Strip Till Points • Fertilizer Row Units

Distributors of:

Belted Grain & Fertilizer Conveyors • Salt & Material Handling Conveyors • Seed Handling Equipment
Round Baler Belting • Milo Guards & Crop Savers

President

Mike Bergmeier – Ext. 301
Email: mjbergmeier@shieldag.com

Vice President

Angie Bergmeier – Ext. 311
Email: acbergmeier@shieldag.com

Sales Manager

Andy Klamm – Ext. 305
Cell: 620-728-8630
Email: adklamm@shieldag.com

Office

General Manager/Engineer
Logan Hurlbut – Ext. 315
Email: lhurlbut@shieldag.com

Inside Sales

Paul Ehler – Ext. 303
Cell: 620-728-8617
Email: prehler@shieldag.com

Accounting/Parts Department

Iris Devena – Ext. 308
Email: iddevena@shieldag.com

Shipping

Brenda Klug – Ext. 304
Email: shipping@shieldag.com

Warranty

Acra-Plant warrants our products to be free of defects in materials and workmanship for a period of 180 days after the date of end user (consumer) purchase from the dealer. The warranty for whole goods equipment shall be exactly the warranty offered on these products by the original equipment manufacturer, and their individual warranties shall replace this warranty. This warranty does not apply to item(s), equipment or component parts that are found to have been subject to abuse or inadequate maintenance, that have been altered in any way or that have been used beyond their advertised capacity, rating or intended use. This warranty shall be for the repair or replacement of the defective item(s) at the sole discretion of Acra-Plant. Any warranty replacement or repairs shall be subject to pro-rated consumer usage deductions as outlined below. Any warranty on tillage items expires after 1/2" of edge wear has occurred. Chrome products are warranted for defects in material and workmanship only, and the pro-rating system and 1/2" edge wear rule does **not** apply to chrome products. Chrome products are not guaranteed for use in rocky or frozen ground. This warranty does not extend to labor incurred in removal or replacement of any item(s). Acra-Plant shall not be liable for incidental or consequential damages arising out of the use or inability to use the item(s) for any purpose whatsoever.

Execution of consumer rights for warranty repair or replacement:

1. Consumer must provide the dealer with evidence of date of purchase of the item(s) to be considered for warranty. This evidence shall be in the form of a copy of the invoice or bill of sale for the item(s) and this evidence shall accompany the item(s) alleged to be defective.
2. The dealer shall provide Acra-Plant with #1, above, and with a copy of the Acra-Plant invoice to the dealer for the same item(s).
3. The Acra-Plant Territory Manager or the dealer shall complete a Acra-Plant Returned Goods Authorization (RGA) for the item(s) alleged to be defective. It is the dealer's responsibility to return the item(s) to Acra-Plant at the dealer's expense; however, the Territory Manager may elect to return the item(s) to Acra-Plant via our truck. Extension of this courtesy does not constitute the final decision to authorize warranty replacement or repair for the item(s).
4. Upon receipt of the item(s) alleged to be defective and the RGA, the Acra-Plant engineering department will inspect the item(s). The engineering department will have sole discretion to authorize warranty replacement or repair.
5. Acra-Plant engineering department shall assign the pro-rated wear factors to all item(s) subject to a warranty claim. Since the range of item(s) varies widely, the assignment of pro-rated wear factor deductions shall be done in good faith, working with the Acra-Plant Territory Manager, the dealer and the consumer. In general, warranty will be pro-rated for wear up to 1/2" of edge wear on the item(s). Any warranty on tillage items expires after 1/2" of edge wear has occurred. The pro-rating system and 1/2" edge wear rule does **not** apply to chrome products.
6. Acra-Plant will at its sole discretion replace or repair the item(s) found to be defective, less the pro-rated wear factors. Acra-Plant will return the item(s) that have been repaired or replaced to the dealer including free return transportation via the mode of our choice.

Notes on Implied Warranties and Limitations

There is no implied warranty of merchantability or fitness for a particular purpose. Some states do not allow limitations on implied warranties of merchantability or fitness for a particular purpose, so this limitation may not apply in a given state. Some states do not allow the exclusion or limitation of incidental or consequential damages, so this limitation may not apply in a given state. This warranty gives dealers and consumers specific rights. There may be other rights that vary from state to state.

Shipments & Returns

This “Shipments and Returns Policy” outlines the rights and obligations of Shield Agricultural Equipment (ShieldAg) dealers with regards to discrepancies in shipments and returns of unsold items to ShieldAg.

Shipments

ShieldAg must be informed of any shortages in shipments within ten (10) days of the arrival of that shipment or shipments at the dealer or end user (in the case of drop-shipments from ShieldAg to the end user). Shortages for truck shipments via LTL, UPS or other common carrier should be forwarded to the carrier for adjustment via freight claim. Shortages deemed by ShieldAg corporate office or our Territory Managers to be our responsibility will be corrected through a credit on the account of the dealer or through replacement of the item(s) that were missing from the shipment. It is the sole responsibility of the dealer to count the item(s) received on shipments and to make appropriate claims for shortages within ten (10) days of the receipt of the item(s).

Execution of dealer rights for shipments:

1. Dealer shall provide ShieldAg with a copy of the ShieldAg packing slip (pick list) highlighting the item(s) that were alleged to be missing. A copy of the packing slip is to be faxed or mailed to ShieldAg within ten (10) days of the receipt of the shipment.
2. The ShieldAg Territory Manager may at our discretion be asked to visit the dealer and examine the shipment and shortage prior to extending credit or replacing the items.
3. ShieldAg will at its sole discretion replace the missing item(s) or credit the dealer account for the net dealer cost of the item(s) found to be missing. If replaced, ShieldAg will replace the missing item(s) to the dealer including free return transportation via the mode of our choice.

Returns

ShieldAg does not have any types of oral or written agreements, contracts or arrangements of any type, between ShieldAg and our dealers or distributors that provide for the rights and obligations of the parties with respect to the purchase or sale of equipment or repair parts, beyond the standard obligations created by purchase orders and acceptance of same, for ShieldAg parts. ShieldAg therefore does not fall under any state’s “buy back” laws. ShieldAg will not allow returns for any items purchased as “special order” or non-standard as modified for a custom application. ShieldAg will accept the return of standard-stocked new item(s) originally purchased into dealer or distributor stock from ShieldAg for a period of two (2) years from the date of original purchase from ShieldAg. All items returned must be current to the stream of commerce and not deemed to be obsolete. Returned item(s) in new and merchantable condition shall be subject to a thirty percent (30%) restocking charge. Any item(s) requiring rework, repackaging or repainting will be accepted only with a revised (and increased) restock charge after inspection at ShieldAg.

Execution of dealer or distributor rights for returned goods:

1. Dealer or distributor shall provide ShieldAg with a copy of the original invoice for the item(s) to be returned and a written explanation of the reason for return.
2. The ShieldAg inside salesperson or territory manager will work with the dealer or distributor to complete a ShieldAg Returned Materials Authorization (RMA), also known in the industry as an RGA (Returned Goods Authorization) for the item(s) to be returned. Upon inspection of the original invoice and the written explanation for return, the ShieldAg Inside salesperson or territory manager will authorize return of the item(s) for inspection and subsequent credit. It is the dealer’s responsibility to return the item(s) to ShieldAg at the dealer’s expense. Receipt of items does not constitute the final decision to extend returned goods credit for the item(s).
3. Upon receipt of the item(s) and the completed RMA (RGA), ShieldAg will inspect the items for merchantability and general condition. Credit on account will only be applied after the items have been inspected and accepted. Credit against the dealer or distributor account receivable will be applied less the thirty percent (30%) restocking charge. There will be no cash refunds for returned items. The ShieldAg territory manager or inside salesperson will communicate (to the dealer or distributor) acceptance (or rejection) of the returned goods and the final credit amount.
4. This Policy dated 12/01/2020 supersedes all previous written or oral Returned Goods policies.

Table of Contents

Acra-Plant Quick Change Side-Mount Fertilizer Knives	Section 1
Acra-Plant Quick Change Fertilizer Knives for Chisel Plow & Field Cultivator Applicators	Section 2
Acra-Plant Hoe Drill Shoes & Hoe Drill Points for OEM Replacement	Section 3
Hoe Drill Shoes	3-1
Hoe Drill Replacement Points	3-7
Chrome Carbide Ripper & Subsoiler Points	Section 4
Conservation Ripper Points	4-3
Chrome Carbide V-Crown Subsoiler & Ripper Points	4-4
Shank Guards, Shin Guards & Ripper Caps	4-11
Acra-Plant V-Slice Inserts	Section 5
Acra-Plant Cultivator Points & Sweeps	Section 6
Acra-Plant Special Application Chrome Carbide	Section 7
OEM Replacement Pin-on Cultivator Points	7-1
Weld-on Cultivator, Sweep, Chisel Plow & Lister Points	7-1
Rod Weeder Points	7-3
Pasture Renovator, Strip Till, Fertilizer & Chisel Plow Points	7-3
Chrome Carbide Harvest Tools	7-5
ShieldAg Pry Bars	Section 8
Casting Crossover Index	Appendix

Fertilizer Knives
Chisel/Cultivator Knives
Hoe Drill
Subsoiler/Ripper
V-Slice Inserts
Cultivator Points/Sweeps
Special Application
Pry Bar
Appendix



Acra-Plant Quick Change Side-Mount Fertilizer Knives

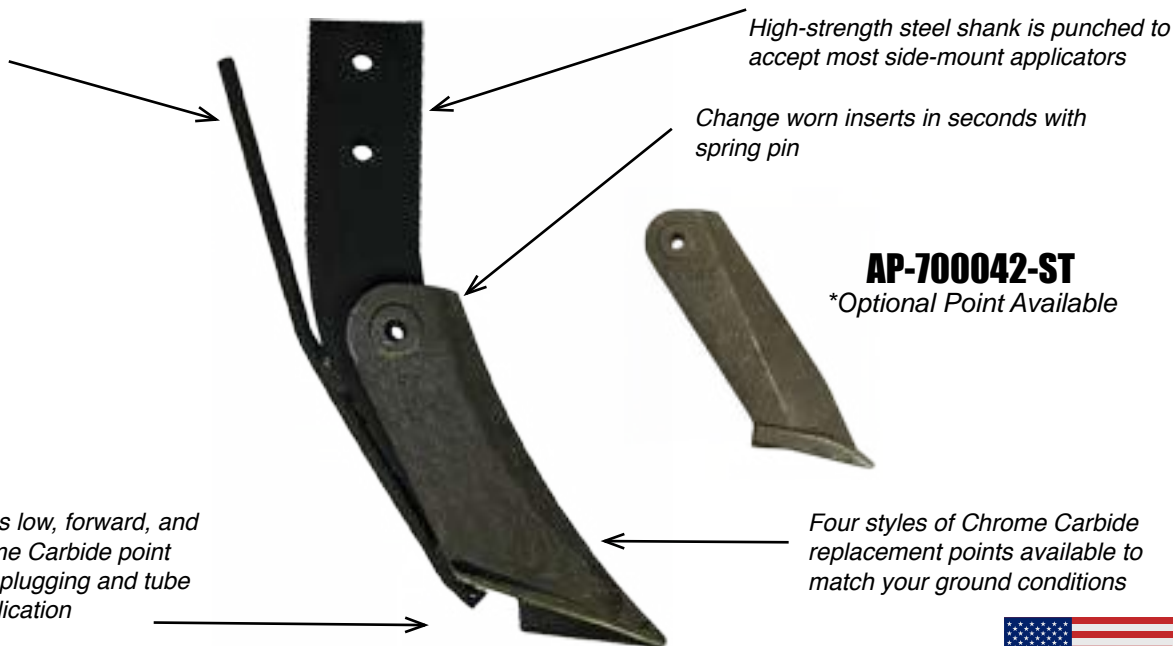

***For other fertilizer knives please call for your distributor**

Features & Benefits

- Acra-Plant replaceable point fertilizer knives outlast “throwaway” knives 3–5 times — reducing downtime and saving money in the long run
- Chrome Carbide Points scour quickly to a high polish, slipping through the soil and pulling easier than “throwaway” knives — you’ll save more fertilizer with the unique self-sealing design
- Acra-Tuff Chrome Carbide alloy point continues to perform like new throughout its life with no degradation of performance after just a few hundred acres
- Acra knives are designed for minimum surface disturbance — perfect for your No-Till cropping plan
- With a choice of three Acra-Tuff Chrome Carbide replacement points and many NH3 and liquid tube options, you can tailor your fertilizer rig to match your conditions and switch very easily if your crop rotation or nutrient plan changes

Acra-Plant Quick Change Side-Mount Fertilizer Knives



Part#	Description	Weight
AP-700010	Side mount shank with 3/8" NH3 tube (.408" OD, for 3/8" NH3 hose) • Other tube options available, see options and replacement parts sections	4.60



AP-700041	Standard fertilizer point with AP-510674 • 3/8" x 1-3/8" spring pin • Self-sealing characteristics with minimum surface disturbance	4.29
-----------	---	------



AP-700042-ST	Super Wing fertilizer point with AP-510674 • 5.0 3/8" x 1-3/8" spring pin • Aggressive hardpan fracturing point	5.0
--------------	---	-----



AP-700043	Super Wing fertilizer point with AP-510674 • 3/8" x 1-3/8" spring pin • Aggressive hardpan fracturing point	4.0
-----------	---	-----



AP-700044	Closer fertilizer point with AP-510674 • 3/8" x 1-3/8" spring pin • Aggressive hardpan fracturing point with added • sealer wing for the toughest sealing conditions	4.69
-----------	---	------

Starter Assemblies

Order ONE PART NUMBER to get started with Acra-Plant Knives:

Kit#	Description	Weight
AP-700000	Assembly includes: AP-700010 shank with 3/8" NH3 tube (.408"OD, for 3/8" NH3 hose) AP-700041 standard point w/AP-510674 3/8" x 1-3/8" spring pin	8.89
AP-700200	Assembly includes: AP-700010 shank with 3/8" NH3 tube (.408"OD, for 3/8" NH3 hose) AP-700043 Super Wing point w/AP-510674 3/8" x 1-3/8" spring pin	8.0
AP-700400	Assembly includes: AP-700010 shank with 3/8" NH3 tube (.408" OD, for 3/8" NH3 hose) AP-700044 sealer point with AP-510674 3/8" x 1-3/8" spring pin	8.0



AP-700000

OPTIONS AVAILABLE to tailor your rig to your ground conditions and nutrient programs or BUILD YOUR OWN SYSTEM from the ground up:

Optional Acra knife shanks (WITHOUT ANY POINT)

Part#	Description	Weight
AP-700010	Shank with single 3/8" NH3 tube crimped and drilled	4.60
AP-700010V	Shank with 3/8" NH3 tube and 3/4" vapor tube	5.40
AP-700011	Bare shank without any tubes	4.00
AP-700011-XBR	Bare shank without any tubes	4.00
AP-702000	Shank with 3/8" NH3 and 3/8" liquid tubes (dual application) Front tube is crimped and drilled, rear tube is open end for liquid	0.50
AP-70200S	Shank with 3/8" NH3 and 3/8" STAINLESS liquid tubes (dual application) Front tube is crimped and drilled, rear tube is open end for liquid	5.10
AP-702010	Shank with 3/8" NH3 and 1/2 liquid tubes (dual application) Front tube is crimped and drilled, rear tube is open end for liquid	5.40
AP-702110	Shank with 3/8" NH3 and clip rings for 1/2" large plastic hose (dual application) Front tube is crimped and drilled and clip rings are welded on	4.80
AP-702510	Shank with single 1/2" NH3 tube (.569" OD), crimped and drilled	4.70
AP-702610	Shank with single 1/2" liquid tube (.569" OD), open end	4.70

NOTE: Specials and vapor tubes (Raven) available on request



Replacement Tubes & Parts

Part#	Description	Weight
AP-700020	3/8" NH3 tube (.408" OD) crimped and drilled	0.50
AP-700021	3/8" Liquid tube (.408" OD) open end	0.50
AP-700022	1/2" Liquid tube (.569" OD) open end	0.60
AP-700023	3/8" NH3 tube (.408" OD) and clip rings for 1/2" large plastic tube	0.60
AP-700025	1/2" NH3 tube (.569" OD) crimped and drilled	0.60
AP-700041	Bare shank without any tubes	4.29
AP-700043	Bare shank without any tubes	4.00
AP-700044	Closer fertilizer point with AP510674 3/8" x 1-3/8" spring pin	4.69
K2TBDA3/4	3/4" Vapor tube (Raven)	0.75
AP-510674	3/8" x 1-3/8" spring pin	0.09



MADE IN THE U.S.A.

Additional Solid Chrome Carbide Coulter Injection



Part#	Description	Weight
K-5SB5SST	Thin Boron knife for Ag Systems (and others) <ul style="list-style-type: none"> • Coulter Injection System comes with UHMW cushions to minimize impact damage • 5/16" Thick Boron Steel Liquid Knife with Surta-Shield® 	5.50
K-7S	Chrome knife for Ag Systems (and others) <ul style="list-style-type: none"> • No weld-on fertilizer steel tube, to reduce impact breakage • Customer just inserts 3/8" liquid hose into self-gripping deep hole cast into knife and ties it off with band clamp or zip tie 	4.35
K-8S	Chrome knife for Ag Systems (and others) <ul style="list-style-type: none"> • No weld-on fertilizer steel tube, to reduce impact breakage • Customer just inserts 3/8" liquid hose into self-gripping deep hole cast into knife and ties it off with band clamp or zip tie 	4.35



MADE IN THE U.S.A.



Acra-Plant Quick Change Fertilizer Knives For Chisel Plow Applicators

Chisel/Cultivator Knives

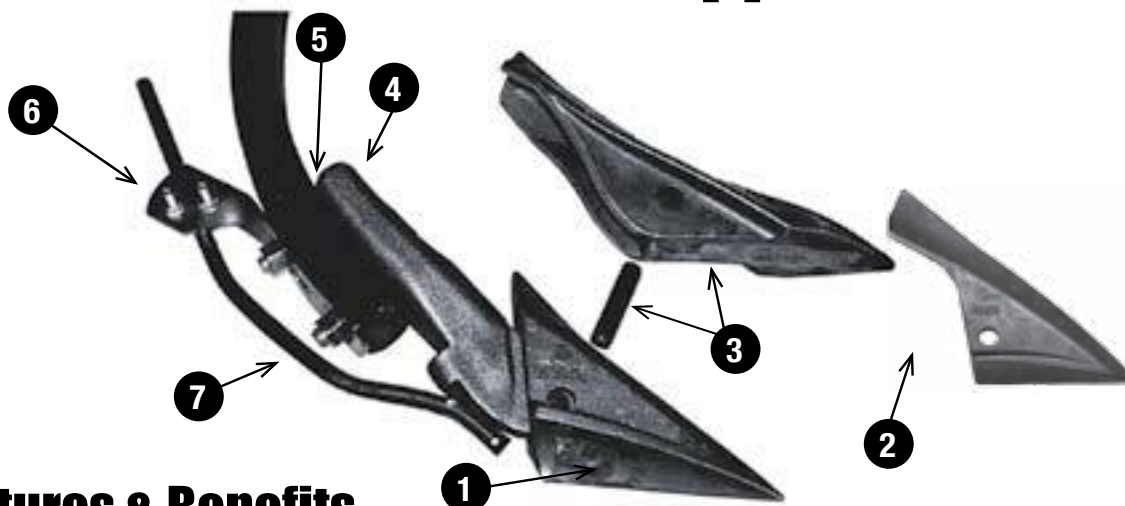

Features & Benefits

- Long-lasting Acra-Tuff Alloy replaceable points outwear “throwaway” chisel knives 3–5 times
- Acra-Tuff continues to perform like new throughout its life, no degradation of performance after just a few hundred acres
- Convert from fertilizer placement to standard chisel in just a few minutes by replacing the AP-708041 fertilizer point with the AP-705141 chisel plow point
- AP-708041 fertilizer point protects your fertilizer tube from plugging, wear and freeze-up
- Tube options available for nearly any NH3 or liquid application
- Set up to accept Acra-Plant Air Seeder assembly AP-718500 for maximum versatility with your chisel plow implement

Part#	Description	Weight
AP-708041	1 Acra-Tuff chrome alloy fertilizer point Includes AP-500657 1/2" x 1-1/4" spirol pin	2.79
AP-705042	2 Acra-Tuff chrome alloy chisel plow point Includes AP-500657 1/2" x 1-1/4" spirol pin	4.71
AP-705141	3 Acra-Tuff chrome alloy chisel plow point Includes AP-500657 1/2" x 1-1/4" spirol pin	4.80
AP-705011	4 Cast Steel Shanks	4.30
AP-708003	5 Adjusting wedge to change shank angle	0.50
AP-705029	6 Tube mounting bracket kit Includes: 1ea AP-705025 bracket 1ea AP-500536 1/4" U-bolt 2ea AP-500580 1/4 Lock Nut	0.50
AP-705021	7 3/8" Liquid tube (.408" OD), open end	0.32





AP-705000 Assembly



AP-705029



Left to right: AP-705027, AP-705021, AP-705023, AP-705024



AP-708041



AP-705042



AP-705141

Starter Assembly

Get started using your chisel plow for fertilizer application

Part#	Description	Weight
AP-705000	Complete shank with point, includes: <ul style="list-style-type: none"> • 1ea AP-705011 HT Steel shank • 1ea AP-708041 Fertilizer point with pin • 1ea AP-708003 Adjusting wedge 	7.50

ORDER 1ea AP-705029 Tube Mounting Bracket Kit PER KNI

AP-705029	Tube mounting bracket kit 0.50 <ul style="list-style-type: none"> • Includes: 1ea AP-705025 bracket • 1ea AP-500536 1/4" U-bolt • 2ea AP-500580 1/4" Lock Nut 	6.50
-----------	--	------

Replacement Tubes

Part#	Description	Weight
AP-705020	3/8" NH3 tube (.408" OD), crimped and drilled	0.32
AP-705021	3/8" Liquid tube (.408" OD), open end	0.32
AP-705022	1/2" Liquid tube (.569" OD), open end	0.34
AP-705023	3/8" NH3 and clip rings for 1/2" large plastic hose (dual application) Tube is crimped and drilled and clip rings vane welded on	0.46
AP-705024	1/2" NH3 tube (.569" OD) crimped and drilled	0.34
AP-705027	3/8" NH3 tube (.408" OD), crimped and drilled with 3 / 4 " Vapor tube welded on	0.79

Replacement Points

Part#	Description	Weight
AP-708041	Acra-Tuff chrome alloy fertilizer point 2.19 Includes AP-500657 1/2" x 1-1/4" spirol pin	2.19
AP-705042	Acra-Tuff chrome alloy fertilizer point Includes AP-500657 1/2" x 1-1/4" spirol pin	4.71
AP-705141	Acra-Tuff chrome alloy chisel plow point 4.80 Includes AP-500657 1/2" x 1-1/4" spirol pin	4.80





Acra Plant Field Cultivator Applicator System

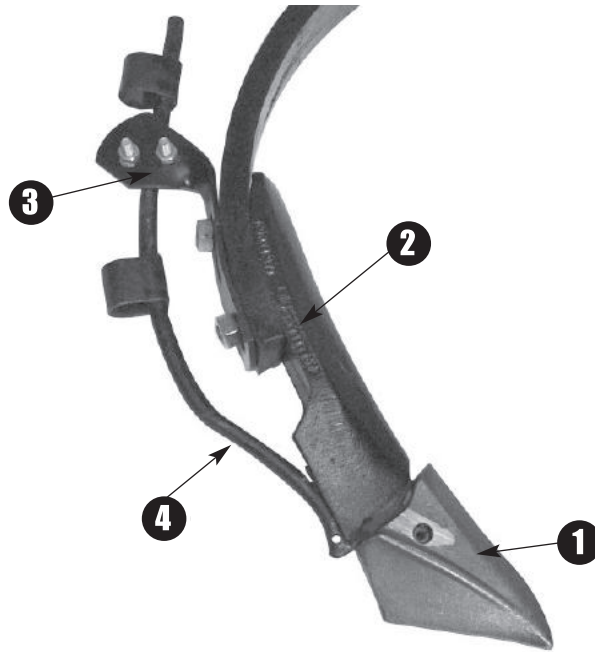

Features & Benefits

- Long-lasting Acra-Tuff Alloy replaceable points outwear “throwaway” points 3–5 times
- Acra-Tuff continues to perform like new throughout its life, no degradation of performance after just a few hundred acres
- AP-710080 fertilizer point protects your fertilizer tube from plugging, wear and freeze-up
- Tube options available for nearly any NH₃ or liquid application
- May be used without tubes for standard cultivator work

Part #	Description	Weight
AP-710080 ❶	Acra-Tuff chrome alloy Z8 fertilizer point Includes AP-510693 5/16" x 1" spring pin	1.15
AP-707611 ❷	Ductile iron field cultivator shank	3.75
AP-705029 ❸	Tube mounting bracket kit shin guard Includes: 1ea AP-705025 bracket 1ea AP-500536 1/4" U-bolt 2ea AP-500580 1/4" Lock Nut	0.50
AP-705023 ❹	3/8" NH ₃ and clip rings for 1/2" large plastic hose (dual application) <i>Tube is crimped and drilled and clip rings are welded on</i>	0.46

NOTE: SEE REPLACEMENT TUBES & PARTS for all of the TUBE OPTIONS



Acra-Plant Quick Change Fertilizer Knife for Field Cultivator Application

Order these Part Numbers for First Time Use

Part #	Description	Weight
1 each AP-707611	Ductile iron field cultivator shank	3.75
1 each AP-710080	Acra-Tuff chrome alloy Z8 fertilizer point Includes AP-510693 5/16" x 1" spring pin	1.15
1 each AP-705029	Tube mounting bracket kit Includes: 1ea AP-705025 bracket 1ea AP-500536 1/4" U-bolt 2ea AP-500580 1/4" Lock Nut	0.50



ADD the Fertilizer Tube of your choice:

Select the Replacement Fertilizer Tube(s) you need from the following:

Part #	Description	Weight
AP-705020	3/8" NH3 tube (.408" OD), crimped and drilled	0.32
AP-705021	3/8" Liquid tube (.408" OD), open end	0.32
AP-705022	1/2" Liquid tube (.569" OD), open end	0.34
AP-705023	3/8" NH3 and clip rings for 1/2" large plastic hose (dual application) <i>Tube is crimped and drilled and clip rings are welded on</i>	0.46
AP-705024	1/2" NH3 tube (.569" OD) crimped and drilled	0.34
AP-705027	3/8" NH3 tube (.408" OD), crimped and drilled with 3 / 4 " Vapor tube welded on	0.79



Left to right: AP-705027, AP-705021, AP-705023, AP-705024

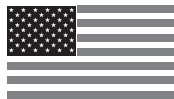

Acra-Plant Knives & Parts are made in the USA

Acra-Plant Hoe Drill Shoes & Hoe Drill Points for OEM Replacement

Retool Your Existing Hoe Drill with Acra-Plant to Improve Performance in Difficult Soil, Moisture & Residue Conditions



- Unique **trash lifters** allow for easier less-till planting
- **Stainless steel** bodies self scour to pull easier without plowing
- **Acra-Tuff** Chrome Carbide Points take the hardest ground

Save on seed — Go deep to find moisture and protect young plants from high winds without plowing the soil or raking your old stubble — plant in the heaviest of residues — **Use Acra V-Slice technology to put the seed where it belongs** this year. With Acra-Plant Hoe Drill Shoes, you can select from up to 5 different points to tailor your Hoe Drill for your ground and residue conditions.



AP-711070

John Deere LZ, 9300
775-785
Air Hoe
Seeders



AP-719480

John Deere 9400
1800-Series
Air Hoe
Seeders



AP-714070

Crustbuster Hoe Drills
with Trash Shank



AP-715070

CaselH 150
w/Cast Boot



AP-715570

CaselH
150 with Fab Boot

Model #	Acra-Plant Shoe with DSZ Point Assembly Part #	Weight
John Deere LZ, 9300, 775-785 air hoe drills (comes with AP-710070 (DSZ7) point installed)	AP-711070	4.08
John Deere 9400, 1800-Series air hoe seeder (comes with AP-710080 (DSZ8) point installed)	AP-719480	5.00
Crustbuster hoe drills with trash shank (comes with AP-710070 (DSZ7) point installed)	AP-714070	4.08
CaselH 150 hoe drills with cast boot (comes with AP-710070 (DSZ7) point installed)	AP-715070	3.50
CaselH 150, 7000-7100-7200 hoe drills with Fab Boot & 8500 air hoe drill (comes with AP-710070 (DSZ7) point installed)	AP-715570	3.33

NOTE: Acra-Plant hoe drill shoes also available for Versatile/Noble drills. Consult factory for details. Installation hardware purchased separately.



Made in the USA

John Deere LZ 9300, 775-785 Air Hoe Drills



AP-711070

Kit#	Description	Weight
AP-711070	Assembly Includes	4.08
	AP-711052 Acra-Plant stainless steel drill shoe body weldment	3.05
	AP-710070 Acra-Tuff chrome carbide V-slice point (DSZ7) with pin	1.03

Parts Required for First Time Installation on John Deere Drills

Part#	Description	AP-711045 Installation Hardware
AP-500044	Seed Baffle 1ea 3/8 x 2 1/2	Carriage Bolt 1ea
5/16 X 1	Hex Head Bolt 1ea 3/8	Top Lock Nut 1ea
5/16	Hex Jam Nut 1ea 5/16 x 2 1/2	Carriage Bolt 1ea
	5/16	Top Lock Nut 1ea

JD LZ/9300 Installation Sheet will be sent with each order for AP-711070

Optional Points & Hardware

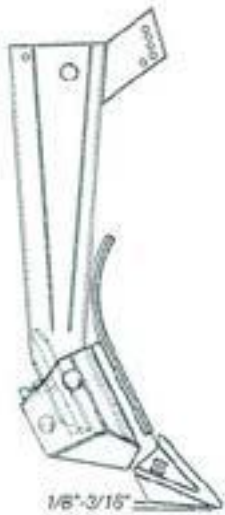

Part#	Description	Weight
AP-710060	(DSZ6) bolt-on V-bottom low disturbance point w/hardware	0.78
AP-710070	(DSZ7) bolt-on V-bottom low disturbance point w/hardware	1.03
AP-729390	Z9 bolt-on flat bottom, drop-nose point without hardware	0.85
AP-729400	Bolt-on-heavy-duty shallow V, drop nose point without hardware	0.90
DNC-715V	Economy bolt-on shallow V, drop nose point without hardware	0.70
AP-510693	5/16" x 1" spring pin (comes with AP-710070)	
N1	1/4" square nut, required for bolt-on points	
Z1-1	1/4" x 1" machine screw slotted flat head, required for bolt-on points	
1-1	Box of 100ea 1/4" x 1" machine screw and 100ea 1/4" square nut	

With Acra-Plant Hoe Drill Shoes, you can select from up to five different points to tailor your Hoe Drill for your ground and residue conditions.
Hard Ground • Heavy Residue • Tough Planting Conditions
Dry Climate • Wet Planting Time
Tailor your Hoe Drill with Acra-Plant for Optimum Performance



John Deere 9400, 1800-Series Air Hoe Seeder

AP-719480 Assembly with AP-710080 (DSZ8) Point

Kit#	Description	Weight
AP-719480	Assembly Includes	5.0
AP-719452	Acra-Plant stainless steel drill shoe body weldment	3.8
AP-710080	Acra-Tuff chrome carbide V-slice point (DSZ8) with pin	1.20
AP-719670	Modified AP-719452 to accept AP-710060 or AP-710070	



AP-719480

Parts Required for First Time Installation on John Deere Drills

Part#	Description	AP-711045 Installation Hardware			
AP-719421	Seed Baffle	1ea	3/8 x 2 1/2	Carriage Bolt	1ea
5/16 X 1	Hex Head Bolt	1ea	3/8	Top Lock Nut	1ea
5/16	Hex Jam Nut	1ea	5/16 x 2 1/2	Carriage Bolt	1ea
			5/16	Top Lock Nut	1ea

JD LZ/9300 Installation Sheet will be sent with each order for AP-711070

Replacement Point & Hardware

Part#	Description	Weight
AP-710080	(DSZ8) pin-on heavy-duty V-slice point with pin	1.20
AP-510693	5/16" x 1" spring pin (comes with AP-710080)	

NOTE: The AP-719480 Acra-Plant Hoe Drill Shoe was designed EXCLUSIVELY for the John Deere 9400-series Hoe Drills and the 1800-Series Air Hoe Seeder. Optimum performance can only be guaranteed using the EXCLUSIVE AP-710080 (DSZ8) Heavy-Duty V-slice point.

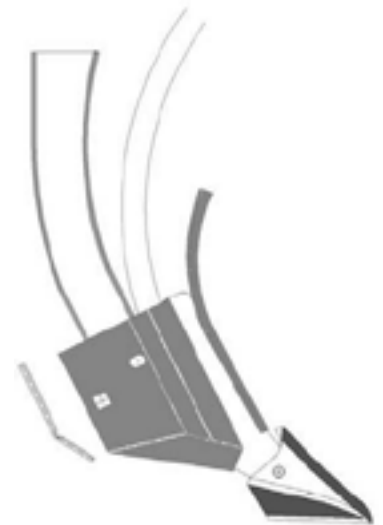

Hoe Drill

Optimize your John Deere Hoe Drill with ACRA-Plant Stainless Steel Hoe Drill Shoes



Crustbuster Hoe Drills Equipped with Trash Shanks

Conversion For Crustbuster to Acra Plant Opener; AP-714070 Assembly with AP-710070



AP-714070

Kit#	Description	Weight
AP-711070	Assembly Includes	4.08
AP-711052	Acra-Plant stainless steel drill shoe body weldment	3.05
AP-710070	Acra-Tuff chrome carbide V-slice point (DSZ7) with pin	1.03

Hardware Installation Kit

Kit#	Description	Quantity
AP-714071	3/8" x 2-1/2" carriage bolt	2
	3/8" top lock nut	2

Crustbuster Installation Sheet will be sent with each order for AP-71407

Optional Points & Hardware for Acra Plant Drill Shoe

Kit#	Description	Weight
AP-710060	(DSZ6) bolt-on V-bottom low disturbance point w/hardware	0.78
AP-710070	(DSZ7) pin-on heavy-duty V-slice point with pin	1.03
AP-729390	Z9 bolt-on flat bottom, drop-nose point without hardware	0.85
AP-729400	Bolt-on-heavy-duty shallow V, drop nose point without hardware	0.90
DNC-715V	Economy bolt-on shallow V, drop nose point without hardware	0.70
AP-510693	5/16" x 1" spring pin (comes with AP-710070)	
N1	1/4" square nut, required for bolt-on points	
Z1-1	1/4" x 1" machine screw slotted flat head, required for bolt-on points	
1-1	Box of 100ea 1/4" x 1" machine screw and 100ea 1/4" square nut	

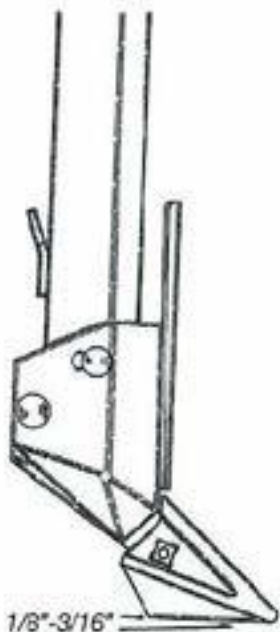

Equip your Crustbuster Hoe Drill with ACRA-Plant Shoes for HIGH PERFORMANCE Less-Till drilling



CaselH 150 Hoe Drills with Cast Shank Boots

AP-715070 Assembly with AP-710070 (DSZ7) Point

Kit #	Description	Weight
AP-715070	Assembly includes:	3.50
	AP-715052 Acra-Plant stainless steel drill shoe body weldment	2.47
	AP-710070 Acra-Tuff chrome carbide V-slice point (DSZ7) with pin	1.03
AP-715071	<i>Hardware Installation Kit</i>	
	Quantity	Description
	2	3/8" x 3/4" Carriage Bolt
	2	3/8" Top Lock Nut



AP-715070

Parts Required for First Time installation on CaselH Drills

Part #	Description	Quantity	Weight
AP-715021	Seed baffle	1	0.20

CaselH 150 Cast Boot Installation Sheet will be sent with each order for AP-715070

Optional Points & Hardware

Part #	Description	Weight
AP-710060	(DSZ6) bolt-on V-bottom low disturbance point with hardware	0.78
AP-710070	(DSZ7) pin-on heavy-duty V-slice point with pin	1.03
AP-729390	Z9 bolt-on flat bottom, drop-nose point without hardware	0.85
AP-729400	Bolt-on heavy-duty shallow V, drop nose point without hardware	0.90
DNC-715V	Economy bolt-on shallow V, drop nose point without hardware	0.70
AP-510693	5/16" x 1" spring pin (comes with AP-710070)	
N1	1/4" square nut, required for bolt-on points	
Z1-1	1/4" x 1" machine screw slotted flat head, required for bolt-on points	
1-1	Box of 100ea 1/4" x 1" machine screw & 100ea 1/4" square nut	

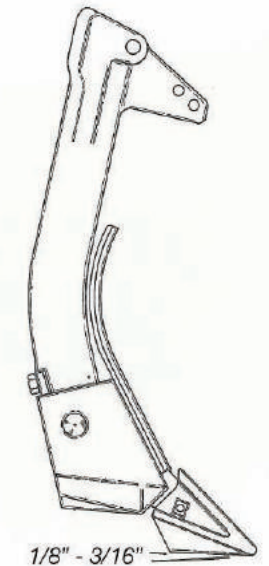

**With Acra-Plant Hoe Drill Shoes,
you can select from up to five different points to tailor your
Case IH Hoe Drill for your ground and residue conditions**

**Hard Ground • Heavy Residue • Tough Planting Conditions
Dry Climate • Wet Planting Time**

Acra-Plant will Tailor your Hoe Drill for Optimum Performance



Acra-Plant Hoe Drill Shoes

CasellH 150 Hoe Drills with Fab Shanks & 7000-7100-7200 Hoe Drills with Fab Shank Boot & 8500 Air Hoe Drill



AP-715570

AP-715570 Assembly with AP-710070 (DSZ7) Point

Kit #	Description	Weight
AP-715570	Assembly includes:	3.33
AP-715552	Acra-Plant stainless steel drill shoe body weldment	2.30
AP-710070	Acra-Tuff chrome carbide V-slice point (DSZ7) with pin	1.03

Optional Parts for First Time

Installation on CasellH Hoe Drills with Fab Boots

Consult Acra Plant Factory Engineering for side plates and seed tube options that may be required for **FIRST TIME** application:

Part #	Description	Quantity
AP-715053	3/8" x 1" hex head cap screw	2
Installation Hardware	3/8" top lock hex nut	2
AP-715523	Short seed tube	1
Optional Seed Tube		

CasellH 150 Fab Boot Installation Sheet will be sent with each order for AP-715570

Optional Points & Hardware

Part #	Description	Weight
AP-710060	(DSZ6) bolt-on V-bottom low disturbance point with hardware	0.78
AP-710070	(DSZ7) pin-on heavy-duty V-slice point with pin	1.03
AP-729390	Z9 bolt-on flat bottom, drop-nose point without hardware	0.85
AP-729400	Bolt-on heavy-duty shallow V, drop nose point without hardware	0.90
DNC-715V	Economy bolt-on shallow V, drop nose point without hardware	0.70
AP-510693	5/16" x 1" spring pin (comes with AP-710070)	
N1	1/4" square nut, required for bolt-on points	
Z1-1	1/4" x 1" machine screw slotted flat head, required for bolt-on points	
1-1	Box of 100ea 1/4" x 1" machine screw & 100ea 1/4" square nut	

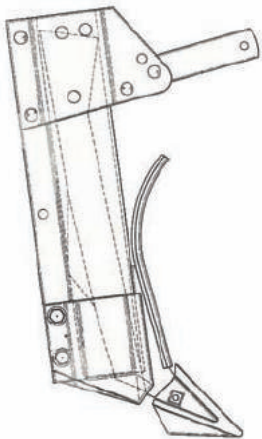

Hoe Drill Replacement Points

Chrome Carbide Drill Points for Acra-Plant Min-Till Hoe Drill Shoes and Quality Chrome Carbide Drill Points to improve the performance of your standard hoe drill:

- **ACRA-Tuff Chrome Carbide Points** take the hardest ground
- **Chrome Carbide will outlast OEM cast points 3-5 times**
- Many points available in V-bottom configuration, for improved seed-soil contact
- **Widest variety of Chrome Carbide Points** to tailor your hoe drill for your ground and residue conditions and for your ever-changing crop rotations

Part Numbers in bold are the Part Numbers you order from Acra-Plant/ShieldAg
Part Numbers in parentheses () are common numbers that have been used by the industry to identify these parts



See castings Cross Reference Index on pages i,ii, iii



AP-710060
(DSZ6)
(Z6)
(AG-7100-60)
(TF111)
(DNC-829)



AP-710070
(DSZ7)
(Z7)
(DNC-827P)



AP-710080
(DSZ8)
(Z8)



AP-729390
(Z9)
(TF132)



AP-729400
(99)



DNC-715V
(715V)



AP-729410
(Z10)
(TF105)
(657PO)



DNC-657D
(657)



DNC-657V
(657V)



DNC-657DEB
(657DEB)



AP-720011X
(720011)
(809i)



AP-720011XV
(809V)



Hoe Drill Replacement Points







Points Available for Acra-Plant Min-Till Hoe Drill Shoes

NOTE: These points are designed for drills that have been converted to Acra-Plant Shoes

Model #	Bolt-On V-Bottom	Pin-On V-Bottom	Bolt-On Flat Bottom	Bolt-On Shallow V	Economy Bolt-On Shallow V
John Deere LZ, 9300, 775-785	AP-710060 (DSZ6, Z6)	AP-710070 (DSZ7, Z7)	AP-729390 (Z9)	AP-729400	DNC-715V (715V)
John Deere 9400, 1800		AP-710080 (DSZ8, Z8)			
CaselH Fab Shank	AP-710060 (DSZ6, Z6)	AP-710070 (DSZ7, Z7)	AP-729390 (Z9)	AP-729400	DNC-715V (715V)
CaselH Cast Shank	AP-710060 (DSZ6, Z6)	AP-710070 (DSZ7, Z7)	AP-729390 (Z9)	AP-729400	DNC-715V (715V)
CrustBuster with Trash Shanks	AP-710060 (DSZ6, Z6)	AP-710070 (DSZ7, Z7)	AP-729390 (Z9)	AP-729400	DNC-715V (715V)
Melroe/Lilliston/ Kirshman/ Massey	AP-710060 (DSZ6, Z6)	AP-710070 (DSZ7, Z7)	AP-729390 (Z9)	AP-729400	DNC-715V (715V)
Noble DK-5 2" shank	AP-710060 (DSZ6, Z6)	AP-710070 DK-5 Boot	AP-729390	AP-729400	
		Because of casting tolerance, sides of boot may have to be ground slightly to allow installation of point			
Versatile 2000-2200 Series		(DSZ8, Z8)			

Hoe Drill

Parts





Part #	Description	Weight
 AP-710060	(DSZ6, Z6) Bolt-on V-bottom point, includes hardware <i>This point is a light-weight, less aggressive Acra-Plant V-bottom point without "drop point" designed for lighter soil applications</i>	0.78
 AP-710070	(DSZ7, Z7) Pin-on V-bottom point with 5/16" x 1" spring pin <i>This point is a heavy-duty aggressive Acra-Plant V-bottom point designed for optimum seed-to-soil contact in the toughest planting conditions</i>	1.03
 AP-710080	(DSZ8, Z8) Pin-on V-bottom point with 5/16" x 1" spring pin <i>This point is a heavy-duty aggressive Acra-Plant V-bottom point designed for optimum seed-to-soil contact in the toughest planting conditions</i>	1.20
 AP-729390	(Z9, TF132) Bolt-on flat bottom point, without hardware <i>This point is designed with a "drop nose" tip for any Z6 or Z7 application where the V-bottom is not desired due to ground or soil conditions</i>	0.85
 AP-729400	Bolt-on V-bottom point with "drop nose," without hardware <i>This point is designed with a "drop nose" tip for any Z6 or Z7 application where the V-bottom is desired with a drop point</i>	0.90
 DNC-715V	(715V) Bolt-on "economy" V-bottom point, without hardware <i>This point is a light-weight, less aggressive V-bottom point with a small "drop point" designed for lighter soil applications</i>	0.70

Hardware

Part #	Description
AP-510693	5/16" x 1" spring pin (comes with AP-710070)
N1	1/4" square nut, required for bolt-on points
Z1-1	1/4" x 1" machine screw slotted flat head, required for bolt-on points
1-1	Box of 100ea 1/4" x 1" machine screw & 100ea 1/4" square nut

Hoe Drill Replacement Points





Points Available for John Deere OEM Hoe Drill Shoes

Model #	Standard Bolt-On Spear Point	Drop Nose Pin-On Flat Bottom	Drop Nose Bolt-On Flat Bottom	Spear Point Bolt-On V-Bottom
John Deere LZ John Deere 9300, 9400 with factory AN213462 boot & air hoe seeders	DNC-657D (657)	AP-729410 (Z10) (TF105) (657PO)	DNC-657DEB (657DEB)	DNC-657V (657V)
				

NOTE: John Deere OEM Boot Part Number AN213462 is now the only factory OEM boot available from John Deere for LZ, 9300 and 9400-series Hoe Drills. The above list of points are designed to yield the widest variety of Spear Points and V-bottom Points available today for all John Deere Hoe Drills and air hoe seeders using hoe drill boots.

Hoe Drill

Parts

Part #	Description	Weight	
DNC-657D	(657) John Deere bolt-on spear point without hardware <i>The Spear Point is designed to replace the standard JD Spear Point and is a direct replacement for original LZ shoes</i>	0.75	 DNC-657D
AP-729410	(657PO, TF105, Z10) pin-on flat bottom point without hardware <i>This point is designed with a "drop nose" tip for harder ground conditions and is a direct replacement for original LZ shoes</i>	0.82	 AP-729410
DNC-657DEB	(657DEB) "Drop-nose" bolt-on spear point without hardware <i>This drop nose spear point is designed to replace the standard JD spear point in applications where customers require a shorter point while retaining the "drop point" design. Normally, all points must be replaced to use DNC-657DEB due to the shorter point design.</i>	0.78	 DNC-657DEB
DNC-657V	(657V) Extended nose V-bottom bolt-on point without hardware <i>This V-bottom Spear Point is designed to replace the standard JD Spear Point where a V-bottom design is required</i>	0.86	 DNC-657V

Hardware

Part #	Description
N1	1/4" square nut, required for bolt-on points
Z1-1	1/4" x 1" machine screw slotted flat head, required for bolt-on points
1-1	Box of 100ea 1/4" x 1" machine screw and 100ea 1/4" square nut



Made in the USA

Points Available for CaseIH/International OEM Hoe Drill Shoes

Model#	Extreme Condition Bolt On Point	Bolt-On V-Bottom
CaseIH/International	AP-720011X (720011) (809i)	AP-720011XV

Parts

Part#	Description	Weight
AP-720011X	(Z11X) Z11 extreme conditions bolt-on point, without hardware This point features a more radical nose drop and a taller V-crown to last longer in dry, hard conditions	0.90
AP-720011XV	Bolt-on V-bottom point, without hardware This point is a V-bottom version of the standard Z11	1.04



Hardware

Kit#	Description
N1	1/4" square nut, required for bolt-on points
Z1-3	1/4" X 1-1/2" machine screw slotted flat head, required for bolt-on points



MADE IN THE U.S.A.

Points Available for Crustbuster OEM Hoe Drill Shoes

Model #	Economy Bolt-On Point	Drop Nose Bolt-On V-Bottom
Crustbuster	AP-729390 (Z9, TF132)	AP-729400

Parts

Part #	Description	Weight
AP-729390	(Z9, TF132) Bolt-on flat bottom point, without hardware <i>This point is designed with a "drop nose" tip</i>	0.85
AP-729400	Bolt-on V-bottom point with "drop nose", without hardware <i>This point is designed with a "drop nose" tip for any Z6 or Z7 application where the V-bottom is desired with a drop point</i>	0.90

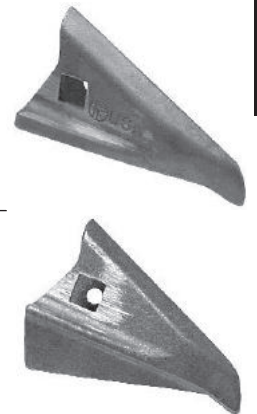

Hoe Drill

Hardware

Part #	Description
N1	1/4" square nut, required for bolt-on point
Z1-1	1/4" x 1" machine screw slotted flat head, required for bolt-on points
1-1	Box of 100ea 1/4" x 1" machine screw and 100ea 1/4" square nut

Optional Points for Early Crustbuster Hoe Drills with 3/8" shank and bolt-on point or pin-on options

Part #	Description	Weight
AP-710060	(DSZ6, Z6) Bolt-on V-bottom point with hardware	0.78
AP-710070	(DSZ7, Z7) Pin-on V-bottom point with 5/16" x 1" spring pin	1.03

Hoe Drill Replacement Points

Points Available for Great Plains, My-D Han-D & Morris OEM Hoe Drill Shoes

Model #	Standard Bolt-On Point	Drop-Nose Bolt-On V-Bottom	Bolt-On V-Bottom	Pin On V-Bottom
Great Plains, My-D Han-D	AP-729390 (Z9, TF132)	AP-729400	AP-710060	
Morris-MH310 Morris Edge on Shank	AP-729390	AP-729400	AP-710060	AP-710080

Parts

Part #	Description	Weight
AP-729390	(Z9, TF132) Bolt-on flat bottom point, without hardware <i>This point is designed with a "drop nose" tip</i>	0.85
AP-729400	Bolt-on V-bottom point with "drop nose", without hardware	0.90

Hardware

Part #	Description
N1	1/4" square nut, required for bolt-on points
Z1-1	1/4" x 1" machine screw slotted flat head, required for bolt-on points
1-1	Box of 100ea 1/4" x 1" machine screw and 100ea 1/4" square nut

Optional Points for Early Great Plains Hoe Drills

Part #	Description	Weight
AP-729400		1.03
DNC-715V	(715V) Bolt-on "economy" V-bottom point without hardware	0.70

NOTES: AP-710080 (DSZ8) only for drills with 1/2" shank option
No roll pin for Great Plains drill point

WARNING NOTE: Check your application carefully before ordering. A trial fit may be needed to assure the correct fit with all points listed above

Hoe Drill Replacement Points

Points Available for Versatile & Versatile/Noble Hoe Drills

Model #	Standard Bolt-On Spear Point	Drop Nose Pin-On Flat Bottom	Drop Nose Bolt-On Flat Bottom	Spear Point Bolt-On V-Bottom
Versatile 2000-2200	DNC-657D (657)	AP-729410 (Z10) (TF105) (657PO)	DNC-657DEB (657DEB)	DNC-657V (657V)

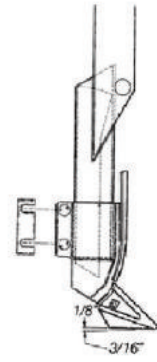

Acra Style Boot
(3/8"-1/2" Foot)

Parts

Part #	Description	Weight
DNC-657D	(657) Bolt-on spear point, without hardware	0.75
AP-729410	(657PO, TF105, Z10) Pin-on flat bottom point, without hardware	0.82
DNC-657DEB	(657DEB) "Drop-nose point" bolt-on spear point, without hardware	0.78
DNC-657V	(657V) Extended nose V-bottom bolt-on point, without hardware	0.86



DNC-657D



AP-729410



DNC-657DEB



DNC-657V

Hardware

Part #	Description	Weight
N1	1/4" square nut, required for bolt-on points	per 500
Z1-1	1/4" x 1" machine screw slotted flat head, required for bolt-on points	per 500
1-1	Box of 100ea 1/4" x 1" machine screw and 100ea 1/4" square nut	per 100

Point for Versatile 2000-2200 Series with Acra-Plant, 1/2" Shoe Foot

Part #	Description	Weight
AP-710080	(DSZ8, Z8) Pin-on V-bottom point with pin	1.20

NOTE: Acra-Plant hoe drill shoes also available for Versatile/Noble drills. Consult factory for details.



AP-710080

Point for very early 2000-series Versatile, 3/8" Foot

Part #	Description	Weight
AP-710060	(DSZ6, Z6) Bolt-on V-bottom point with hardware	0.78
AP-710070	(DSZ7, Z7) Pin-on V-bottom point with pin	1.03



AP-710060



AP-710070

WARNING NOTE: Check your application for Versatile & Versatile/Noble hoe drills carefully before ordering. A trial fit may be needed to assure the correct fit with all points listed above

Chrome Carbide Hoe Drill Points



AP-710060



AP-710070



AP-710080



AP-720011XV



AP-729390



AP-729400



AP-729410

Part#	Description	Weight
AP-710060	(DSZ6, Z6) bolt-on V-Bottom, with hardware	0.78
AP-710070	(DSZ6, Z6) pin-on V-slice, with pin	1.03
AP-710080	(DSZ6, Z6) pin-on V-slice, point with pin	1.20
AP-720011X	(Z11X) bolt-on extreme conditions, without hardware	0.90
AP-720011XV	(Z11X) bolt-on extreme conditions, without hardware	1.04
AP-729390	(Z9, TF132) bolt-on drop-nose without hardware	0.85
AP-729400	Bolt-on V-bottom, drop-nose without hardware	0.90
AP-729410	(Z10, 657PO, TF105) pin-on without hardware	0.82



Chrome Carbide Hoe Drill Points

Part#	Description	Weight
DNC-657D	(657) bolt-on spear, without hardware	0.75
DNC-657DEB	(657DEB) drop nose bolt-on, without hardware	0.78
DNC-657V	(657V) V-bottom bolt-on Spear, without hardware	0.86
DNC-715V	(715V) economy bolt-on shallow V, without hardware	0.70
AP-720011XV	AP-720011XV bolt-on V-bottom point, without hardware	1.04



DNC-657D



DNC-657DEB



DNC-657V



DNC-715V



AP-720011XV

Hoe Drill

Hardware

Part#	Description	Weight
AP-510693	5/16" X 1" Spring pin	
N1	1/4" square nut, required for bolt-on points	
Z1-1	1/4" x 1" machine screw slotted flat head, required for bolt-on points	
Z1-3	1/4" x 1-1/2" Machine screw slotted flat head	
1-1	Box of 100ea 1/4" x 1" machine screw and 100ea 1/4" square nut	



Chrome Carbide Ripper & Subsoiler Points

Acra-Plant/ShieldAg offers a full line of Chrome Carbide ripper and subsoiler points designed to handle tough, dry and hard ground conditions. We manufacture and stock points, shank guards, ripper caps and edge protectors for just about every make and model of subsoiler and disc ripper. Tough conditions that tear up and wear out stock/OEM points are **NO PROBLEM** for our exclusive Chrome Carbide designs.

ShieldAg combines proven Acra-Plant technology with up-to-date ShieldAg Engineering to provide long-lasting, self-sharpening Chrome Carbide deep tillage tools. All parts are made in the USA using the finest quality materials and a chrome carbide chemistry designed exclusively for our Midwest soil types. ShieldAg Chrome Carbide Ripper and Subsoiler Points are designed to last two to three times longer than the Original Equipment parts, and they self scour, wear sharp, and deflect soil flow away from the shank. Your customer saves on down-time, fuel and shank wear, adding dollars to their bottom line. Many different bolt-on, pin-on, and weld-on shank guards are designed just for most Rippers or Subsoilers.

ShieldAg Chrome Carbide ripper points are available for inter-row and shallow subsoiler applications. Our unique nose design takes the hardest ground and wears sharp. The crown reduces slabbing and diverts soil away from the shank to minimize wear. Chrome Carbide scours as it wears sharp to pull easier and reduce topsoil disturbance.

The farmer needing to deep rip with more lift and shattering between shanks will want one of our many types of "winged" ripper points. The scouring action of our Chrome Carbide will reduce fuel costs because the ripper will pull more easily.

Chrome Carbide Pin-on, clamp-on and weld-on shank guards are available for almost any shank. Chrome Carbide weld-on ripper caps are available from the factory on our alloy ripper point assemblies, or the cap can be sold separately for repairs and the do-it-yourself farmer.

Acra-Plant/ShieldAg Chrome Carbide tillage tools are perfect for tough ground conditions and conservation tillage plans.





Acra-Plant is Proud to Introduce the Future of Subsoiling Technology with our **NEW LINE** of Conservation Ripper Points.

Does your Conservation Tillage Yield improvement Program include Subsoiling or Disc/Ripping to relieve compaction zones and improve soil tilth?

Acra-Plant has your answer with our NEW LINE of CRP Points designed to:

- **Relieve soil compaction zones for YIELD IMPROVEMENT**
- **Improve SOIL TILTH to increase nutrient availability and root uptake**
- **Produce a subsoil profile that assures improved root penetration**
- **Assure moisture retention in the driest conditions**
- **Provide fracture and lift with little surface disruption or "slabbing"**
- **Allow flexibility in running depth**
- **Scour up, pull easy and flow soil around the shank to reduce wear**
- **Provide long wear life in the widest variety of soil conditions**

The Acra-Plant & ShieldAg line of **CRP** ripper and subsoiler points are designed specifically for Conservation Tillage practices. **CRP** points are available with wings as shown here and without wings for inner row and spring fieldwork. Our unique design allows us to use solid 25% chrome carbide in all of the wear surfaces with mounting boots designed specifically for most popular makes and models of disc rippers and subsoilers. **Start your Conservation Tillage yield improvement program today** by asking for a CRPpoint for your disc ripper or subsoiler.



Acra-Plant Subsoiler & Ripper Parts are made in the USA

Points for Subsoilers & Rippers with 1" Thick Shank

1" Shank Designed for Krause 4650, Hamby, Johnson, Roll-A-Cone

Part#	Description	Weight
TF-103	Spring cultivator point without hardware <ul style="list-style-type: none"> • Shallow inter-row subsoiler point with V-crown design for reduced slabbing and surface sheeting • Krause part number 33-161 • Interchanges with TF-122 (deep tillage point) • Point is 2" wide x 5-1/2" long • Casting # 103 NOTE: BC0001 Fits Both TF-103 & TF-122	2.68



TF-103



TF-104

TF-104	Shin guard for Krause 4650 <ul style="list-style-type: none"> • Krause part number 33-161A • TF-104 is 1-1/4" wide x 13-3/4" long 	6.50
--------	--	------



TF-122

TF-122	Deeper tillage and subsoiler point without hardware <ul style="list-style-type: none"> • Wider version of TF-103 designed for subsoiling • V-crown design for reduced slabbing • Point is 2-1/2" wide x 5-1/2" long • Casting #122 • Interchanges with TF-103 cultivator point 	3.00
--------	--	------

1" Shank Designed for Krause 4650, Hamby, Johnson, Roll-A-Cone

Part#	Description	Weight
AP-800102	Orthman 2" wide point with AP-510730 5/16"x1-3/4" pin <ul style="list-style-type: none"> • Moderate depth (6"-8") with V-crown design • Point is 2-1/4" wide x 6" long • Casting # TF800102 NOTE: This was ShieldAg part number AP-800101. To align part numbers properly, we are changing the part number to AP-800102	3.62



AP-800102



AP-800104

AP-800104	Orthman 4" wide point with AP-510730 5/16"x1-3/4" pin <ul style="list-style-type: none"> • Moderate depth (6"-8") with V-crown design • 4" wide for increased shattering • Point is 4" wide x 6" long • Casting # TF800104 NOTE: This was ShieldAg part number AP-800102. To align part numbers properly, we are changing the part number to AP-800104	4.81
-----------	--	------



AG-8001-DF

AG-8001-DF	Orthman 2" wide dorsal fin subsoiler point without hardware <ul style="list-style-type: none"> • Moderate depth (6"-8") • Dorsal Fin further reduces slabbing and protects shank • Point is 2" wide x 8-1/2" long • Casting # TF800102 	5.00
------------	---	------



AG-801100

AP-801100	Terra-Flow point for shanks with flat shin guard, without hardware <ul style="list-style-type: none"> • Also fits AP-705011 chisel shank • Point is 3-1/4" wide x 8-1/2" long • Casting # 801100 	4.50
-----------	--	------

Subsoiler/Ripper

1" Shank Designed for Big Ox & Lehman Rippers

Part#	Description	Weight
AP-800207	Big Ox ripper pin-on with AP-510730 5/16" x 1-3/4" pin (prior to 1986 "Big Ripper") <ul style="list-style-type: none"> • Deep tillage point 6"-20" with V-crown design for reduced slabbing • This point requires 5/16" hole in shank • Excellent choice to repair worn shanks that will not accept the Big Ox slip-on points • Will replace all 2D5-series Big Ox points • Point is 2-1/4" wide x 7" long, casting #TF800207 	3.33



AP-800207

Part#	Description	Weight
AP-800850	Big Ox Ripper pin-on with AP-510730 5/16" x 1-3/4" pin (1986 and later, including "Big Ripper") <ul style="list-style-type: none"> • Deep tillage point 6"-20" with V-crown • Wide point for aggressive deep tillage 	3.75



AP-800850

Note: Also known as "Big Ox Point 2"

Slip-on points for Big Ox & Lehman Rippers

Part#	Description	Weight
2D5	Big Ox/Lehman slip-on point (prior to 1986 "Big Ripper") <ul style="list-style-type: none"> • Slip-on flat top ductile iron point without any cap • Deep tillage point 6"-20" designed for very rocky soils or for customers building their own points • Point is 1-3/4" wide x 6-1/2" long 	3.25



2D5

1" Shank Designed for Krause 4650, Hamby, Johnson, Roll-A-Cone

Part#	Description	Weight
2D5B	Big Ox/Lehman slip-on point (prior to 1986 "Big Ripper") <ul style="list-style-type: none"> • Slip-on flat top point with flat chrome carbide cap • Deep Tillage point 6"-20" • Point is 2" wide x 7" long 	3.75
2D5BE	Big Ox/Lehman slip-on point (prior to 1986 "Big Ripper") <ul style="list-style-type: none"> • Slip-on extended point with extended chrome carbide cap • Deep Tillage point 6"-20" • Point is 2-1/4" wide x 7-1/2" long 	4.00



2D5B



2D5BE

1" Shank Designed for IHC # 10 & #11, Paulk, Big Ed, W&A

Part#	Description	Weight
AP-800900	V-crown design with AP-500659 3/8" x 2" pin <ul style="list-style-type: none"> • Deep tillage point 6"-20" • Point is 2-1/4" wide x 7" long, casting #800900 	4.30



AP-800900

Subsoiler/Ripper

Points for York Agri Products “Mulcher” Manufactured 1994 & Later

York Agri Products “Mulcher”, Standard Point



TF-8006-011

Part#	Description	Weight
TF-8006-011	York Agri Products V-crown point without hardware • This machine has a 1-1/4" thick shank with a 1" thick footpiece for mounting the ripper point • Deep tillage point (6"-12") • Excellent minimum surface disturbance point • Point is 2-1/4" wide x 10" long • Casting # TF8006-011	5.50

NOTE: For York Agri Products “Mulcher” machines manufactured 1993 and earlier, USE AP-800601, see page 4-7

York Agri Products “Mulcher”, Winged Point



TF-8006-011W

Part#	Description	Weight
TF-8006-011W	York Agri Products winged point without hardware • This machine has a 1-1/4" thick shank with a 1" thick footpiece for mounting the ripper point • Winged version of TF-8006-011 for improved shattering • Point is 6" wide x 10" long • Casting # TF8006-011W	7.40

NOTE: For York Agri Products “Mulcher” machines manufactured 1993 and earlier, USE AP-800601W, see page 4-7

Subsoiler/Ripper



Points for Subsoilers & Rippers with 1-1/4" Thick Shank

Brent, Unverferth, IH #14, Lindsay Dammer–Diker without Dorsal Fin

Part#	Description	Weight
AP-800500	V-crown ripper point with AP-500646 7/16" x 2" pin <ul style="list-style-type: none"> • Deep tillage point (6"–12") • V-crown design for reduced slabbing • Point is 2-3/8" wide x 10-1/2" long • Casting # 800500 	6.33



AP-800500

JD 900, JD950V, P&M, P-K, Laney, Baker, Lehman Big Shank

Part#	Description	Weight
AP-800601	V-crown ripper point with AP-500659 3/8" x 2" pin <ul style="list-style-type: none"> • Acra-Plant's most popular Chrome Point • Deep tillage point (6"–12") • V-crown design for reduced slabbing • An excellent choice for improved deep tillage for most factory 1-1/4" shank deep rippers • Point is 2-1/4" wide x 10" long • Casting # 8006-01 	6.33



AP-800601

Note: For York Agri Products "Mulcher" manufactured 1994 and later, see TF-8006-011 on Page 4-6

JD 900, JD950V, P&M, P-K, Laney, Baker, Lehman Big Shank & Other 1-1/4" Shanks

Part#	Description	Weight
AP-800601W	V-crown ripper point with wings with AP-500659 3/8" x 2" pin <ul style="list-style-type: none"> • Deep tillage point (6"–12") • V-crown design for reduced slabbing • All of the features of the AP-800601 with wings added for additional shattering capability—great for fracturing really dry, hard ground • Point is 6" wide x 10" long • Casting #8006-01W 	6.40



AP-800601W

Note: For York Agri Products "Mulcher" manufactured 1994 and later, see TF-8006-011W on Page 4-6

Brent, Unverferth, IH #14, Lindsay Dammer–Diker without Dorsal Fin

Part#	Description	Weight
AP-800800	V-crown ripper point with AP-500659 3/8" x 2" pin <ul style="list-style-type: none"> • Deep tillage point (6"–12") • V-crown design for reduced slabbing • Point is 2-1/4" wide x 10" long 	5.50



AP-800800

Bush Hog Dorsal Fin Point

Part#	Description	Weight
TF-81322	Deep tillage point 6"–20", without hardware <ul style="list-style-type: none"> • Dorsal fin reduces slabbing and protects shank • Point is 2" wide x 9" long 	6.50



TF-81322

Acra-Plant offers the ONLY full line of V-Crown Chrome Carbide Ripper Points for machines with 1-1/4" shanks

Subsoiler/Ripper

Points for Subsoilers & Rippers with 1-1/4" Thick Shank

Brent, Unverferth, IH #14, Lindsay Dammer–Diker without Dorsal Fin

Part#	Description	Weight
AP-800500	V-crown ripper point with AP-500646 7/16" x 2" pin <ul style="list-style-type: none"> • Deep tillage point (6"–12") • V-crown design for reduced slabbing • Point is 2-3/8" wide x 10-1/2" long • Casting # 800500 	6.33



AP-800500

JD 900, JD950V, P&M, P-K, Laney, Baker, Lehman Big Shank

Part#	Description	Weight
AP-800601	V-crown ripper point with AP-500659 3/8" x 2" pin <ul style="list-style-type: none"> • Acra-Plant's most popular Chrome Point • Deep tillage point (6"–12") • V-crown design for reduced slabbing • An excellent choice for improved deep tillage for most factory 1-1/4" shank deep rippers • Point is 2-1/4" wide x 10" long • Casting # 8006-01 	6.33



AP-800601

Note: For York Agri Products "Mulcher" manufactured 1994 and later, see TF-8006-011 on Page 4-6

JD 900, JD950V, P&M, P-K, Laney, Baker, Lehman Big Shank & Other 1-1/4" Shanks

Part#	Description	Weight
AP-800601W	V-crown ripper point with wings with AP-500659 3/8" x 2" pin <ul style="list-style-type: none"> • Deep tillage point (6"–12") • V-crown design for reduced slabbing • All of the features of the AP-800601 with wings added for additional shattering capability—great for fracturing really dry, hard ground • Point is 6" wide x 10" long • Casting #8006-01W 	6.40



AP-800601W

Note: For York Agri Products "Mulcher" manufactured 1994 and later, see TF-8006-011W on Page 4-6

Brent, Unverferth, IH #14, Lindsay Dammer–Diker without Dorsal Fin

Part#	Description	Weight
AP-800800	V-crown ripper point with AP-500659 3/8" x 2" pin <ul style="list-style-type: none"> • Deep tillage point (6"–12") • V-crown design for reduced slabbing • Point is 2-1/4" wide x 10" long 	5.50



AP-800800

Bush Hog Dorsal Fin Point

Part#	Description	Weight
TF-81322	Deep tillage point 6"–20", without hardware <ul style="list-style-type: none"> • Dorsal fin reduces slabbing and protects shank • Point is 2" wide x 9" long 	6.50



TF-81322

Acra-Plant offers the ONLY full line of V-Crown Chrome Carbide Ripper Points for machines with 1-1/4" shanks

Subsoiler/Ripper

Acra-Plant Chrome Carbide V-Crown Subsoiler & Ripper Points

JD 900, JD950V, P&M, P-K, Laney, Baker, Bush Hog,
Lehman Big Shank, Quinstar & other 1-1/4" shanks



342-JD-238

Part#	Description	Weight
342-JD-238	Pin-on flat top point, 2-3/8" wide cap without hardware <ul style="list-style-type: none"> • An excellent choice for improved deep tillage for most factory 1-1/4" shank deep rippers • An economical choice for deep ripping work • Point is 2-1/2" wide x 12" long • Casting # TF 238 12 	6.25
342-JD-278	Pin-on flat top point, 2-7/8" wide cap without hardware <ul style="list-style-type: none"> • An excellent choice for improved deep tillage for most factory 1-1/4" shank deep rippers • An economical choice for deep ripping work • Point is 3" wide x 12" long • Casting # TF 278 12 	6.75

Note: These ripper points will interchange in applications using AP-800601 or AP-800601W solid chrome carbide points

M&W & Sunflower Rippers & Disc Rippers with 1-1/4" Shank



342-MW-238

Part#	Description	Weight
342-MW-238	York Agri Products winged point without hardware <ul style="list-style-type: none"> • This machine has a 1-1/4" thick shank with a 1" thick footpiece for mounting the ripper point • Winged version of TF-8006-011 for improved shattering • Point is 6" wide x 10" long • Casting # TF8006-011W 	6.25
TB0034	Pin-on flat top point, 2" wide cap without hardware <ul style="list-style-type: none"> • An excellent choice for improved inner row tillage • An economical choice for deep ripping work • Casting # TF1786 or B-178-6 	
AP-800850	Pin-on flat top point, 1-15/16" wide cap without hardware <ul style="list-style-type: none"> • An excellent choice for improved inner row tillage • An economical choice for deep ripping work • Casting # TF117 or F-200-4 	
BC0001	B-C Ripper to Acraplant Adapter <ul style="list-style-type: none"> • An excellent choice for improved inner row tillage • An economical choice for deep ripping work 	

Notes: This ripper point will interchange with CRP-4 if customer desires Conservation Ripper Point
42-MW-278 also available

V-Crown Subsoiler & Ripper Points for Machines with 1-1/2" Thick Shank

Caldwell, Graber & Laney Rippers



AP-800700

Part#	Description	Weight
AP-800700	V-crown ripper point with AP-500658 1/2 x 2-1/4" pin <ul style="list-style-type: none"> • Deep rillage point (6"-12") • V-crown design for reduced slabbing • Point is 2-1/2" wide x 11-1/2" long • Casting # TF800700 	8.50

Landoll 1600, Brillion 1-1/2 Shank, Older Model Tebben Rippers with 1-1/2" shank Tye & Bigham Brothers



TF-123

TF-123	Point for Tye & Bigham Brothers, without hardware <ul style="list-style-type: none"> • ParaTill/ParaPlow offset shank rippers • Point is 2-1/2" wide x 8" long • Casting # TF123 	6.10
--------	--	------

Specialty Points for OEM Replacement

The Acra-Plant Line of Blu-Jet Points have been redesigned to optimize the fit, lower draft requirements, improve the attack angle and provide more protection of the shank bottom

Blu-Jet Sub Tillers

Part#	Description	Weight
AP-801300	Inner-row point (also considered "spring point") <ul style="list-style-type: none"> • Narrow point for deep tillage • V-crown chrome carbide point scours up quickly and pulls easily • Point is 2" wide x 14" long • Casting # TF801300 	11.00



AP-801300

NOTE: Uses factory hardware, not supplied by Acra-Plant

Part#	Description	Weight
AP-801400	Wide point (also considered "Fall point") <ul style="list-style-type: none"> • Wider point for deeper tillage, more shattering action • V-crown chrome carbide point scours up quickly and pulls easily • Designed to run "nose-down" for optimum performance • Point is 2-7/8" wide x 15-1/2" long • Casting # TF801400 	16.00



AP-801400

NOTE: Uses factory hardware, not supplied by Acra-Plant

Part#	Description	Weight
AP-801600	Shin guard for Blu-Jet sub tiller <ul style="list-style-type: none"> • Improved casting chemistry to resist breakage • Guard is 1-1/4" wide x 22" long 	14.50



AP-801600

NOTE: Uses factory hardware, not supplied by Acra-Plant

Part#	Description	Weight
AP-503300	Blu-Jet Spring (OEM) <ul style="list-style-type: none"> • Replaces casting # BJ3ASPRING/5033 or AP5033 	7.0



AP-503300

AP-503200	Blu-Jet FALL (OEM) <ul style="list-style-type: none"> • Replaces casting # BJ3AFALL/5032 or AP5032 	13.6
-----------	---	------



AP-503200

Subsoiler/Ripper

Acra-Plant Chrome Carbide V-Crown Subsoiler & Ripper Points



AP-800106



TF-820102



TF-820108



TF-129



AP-20406

Part#	Description	Weight
AP-800106	<ul style="list-style-type: none"> • Orthman Strip-Till point • Diamond nose • Tapered 2 1/2" Wing • Use on 1" wide shanks • Improves upon Orthman part number 164-057 	11.80

Acra-Plant VPS Rippers

Optimize the performance of your VPS 2000 or VPS 3000 Ripper with Original Acra-Plant Chrome Carbide Points and Nickel Alloy Shin Guards

VPS 2000 – 1-Hole Shank Mount

Part#	Description	Weight
TF-820102	V-crown point with wings, VPS 2000 <ul style="list-style-type: none"> • Point is 3" wide x 9" long • Casting # TF820102 	5.60
TF-820101	V-Crown Point, without wings, VPS 2000 <ul style="list-style-type: none"> • Same as TF-820102, without wings • Point is 1-3/4" wide x 9" long • Casting # TF820101 	4.80

NOTE: All VPS Ripper Points use factory hardware, not supplied by Acra-Plant.

VPS 3000 – 2-Hole Shank Mount

Part#	Description	Weight
TF-820108	V-crown point with wings, VPS 3000 <ul style="list-style-type: none"> • Point is 4" wide x 10" long • Casting # TF820108 	10.21

NOTE: All VPS Ripper Points use factory hardware, not supplied by Acra-Plant.

Part#	Description	Weight
TF-129	Nickel alloy shin guard for VPS 2000 and VPS 3000 <ul style="list-style-type: none"> • Replaces AP-820106 and TF-820106 • TF-129 is also designed for Quinstar, Baker and P-K rippers • TF-129 is 1-1/4" wide x 22-1/2" long 	10.10

NOTE: We have improved the casting chemistry for 2004 to resist breakage in rocky or hard/frozen ground. Uses factory hardware, not supplied by Acra-Plant.

Replacement Shanks available for VPS Rippers

Part#	Description	Weight
AP-10420	1 1/4" Shank for VPS 2000	132.0
AP-20406	1-1/4" Shank for VPS 3000	88.0

NOTE: Improved using abrasion-resistant High Strength Steel.
* Special Order Only

Subsoiler/Ripper

Acra-Plant Nickel Alloy Shank Guards (Shin Guard) to replace cast OEM Shank Guards.

OEM Replacement Shank guards have been IMPROVED for 2010 using the latest in Nickel Alloy casting technology to improve resistance to fracture in rocky, frozen and hard ground with little degradation in wear life compared to Chrome Carbide.

Part#	Description	Weight
TF-104	Shin Guard for Krause 4650 <ul style="list-style-type: none"> • Krause part number 33-161A • TF-104 is 1-1/4" wide x 13-3/4" long 	6.50

NOTE: Uses factory hardware, not supplied by Acra-Plant

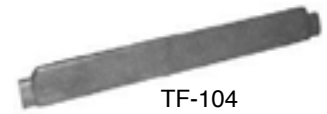

Part#	Description	Weight
AP-801600	Shin Guard for Blu-Jet Sub Tiller <ul style="list-style-type: none"> • Guard is 1-1/4" wide x 22" long 	14.50

NOTE: Uses factory hardware, not supplied by Acra-Plant



Part#	Description	Weight
TF-129	Shin Guard for VPS 2000 and VPS 3000 <ul style="list-style-type: none"> • Replaces AP-820106 and TF-820106 • TF-129 is also designed for Quinstar, Baker and P-Krippers • TF-129 is 1-1/4" wide x 22-1/2" long 	14.50

NOTE: Uses factory hardware, not supplied by Acra-Plant



Subsoiler/Ripper

Weld-On Shank Guards & Wear Plates

Acra-Plant Alloy Weld-on Shank Guards and Wear Plates protect or repair worn Subsoiler/ Ripper Shanks. Weld-on Shank Guards are segmented so that they may easily be broken into sections to work on parabolic and odd-shaped shanks. These guards offer an economical way to protect ripper shanks and repair worn shanks. Our unique Chrome Carbide chemistry scours quickly and the segmented design breaks up dirt flow to minimize slabbing. All guards are cast to be slightly wider than the shanks they protect to avoid scouring of the welds. Use 7018 welding rod or Low Hydrogen Wire to weld these guards on.

Flat Top Weld-On Sectional Guards

Part#	Description	Weight
SG-114-9	Flat top sectional guard, 1" wide x 9" long <ul style="list-style-type: none"> • Use on 3/4" wide shanks 	1.00
SG-112-9	Flat top sectional guard, 1-1/2" wide x 9" long <ul style="list-style-type: none"> • Use on 1-1/4" wide shanks 	1.10
SG-175-7	Flat top section guard, 1-3/4" wide x 7" long <ul style="list-style-type: none"> • Use on 1-1/2" wide shanks 	1.00



Half-Round Weld-On Sectional Guards



SGR-114-14

Part#	Description	Weight
SGR-114-14	Half-round sectional guard, 1-1/4" wide x 12" long • Use on 1" wide shanks	1.10
SGR-138-12	Half-round sectional guard, 1-3/8" wide x 12" long • Use on 1" or 1-1/4" wide shanks	1.80
SGR-112-14	Half-round sectional guard, 1-1/2" wide x 12" long • Use on 1-1/4" wide shanks	1.20

Weld-On Shank Wear Plates, 3" x 6" x 5/16" thick



TF-147L

Part#	Description	Weight
TF-147L	Left-hand wear plate, weld-on, 15° parallelogram	1.60
SGR-138-12	Right-hand wear plate, weld-on, 15° parallelogram • Wear plates for just about any 15-degree straight shank • Beveled front edge to improve soil flow	1.60

Acra-Plant Alloy Weld-on Ripper Caps & Edge Guards

Weld-on Chrome Carbide ripper caps offer an economical way to renew worn ripper points or build custom points to suit individual needs. Flat caps work great to extend the life of moldboard plow landsides and shares. Use 7018 welding rod or Low Hydrogen Wire to weld these caps on.

Weld-On Flat Ripper Caps (wear caps), 5/16" Thick x 4" Long

Part#	Description	Weight
F-200-4	2" wide	0.70
F-212-4	2-1/2" wide	0.88



Weld-On Bump-Nose Ripper Caps

These caps are similar to flat caps with the addition of a light bump at the nose to offer extended wear protection when used on rippers

Part#	Description	Weight
B-178-6	1-7/8" wide x 6" long	1.70
B-238-12	2-2/8" wide x 12" long	3.50
B-238-12	2-7/8" wide x 12" long	3.88



BE-278-12

Weld-On Bump-Nose Ripper Caps with Bevel Front

These caps are similar to Bump-nose caps with the addition of a ledge at the nose to fit over the ripper point base

Part#	Description	Weight
BE-238-7	2-3/8" wide x 7" long	2.25
BE-278-12	2-7/8" wide x 12" long	4.10



BE-278-12



Subsoiler/Ripper

Acra-Plant & ShieldAg offer the Widest Selection of High-Value Chrome Carbide Subsoiler & Ripper Points & Repair Parts in the Tillage Industry

Chrome Carbide General Application Edge Protectors

Part#	Description	Weight
SI-12	1"x 14" V-nose with 1/2" x 3/16" weld-on step <ul style="list-style-type: none"> SI-series V-nose edge protectors are perfect for potato digger blades 	1.11
SI-12HD	1-3/4" x 12" V-nose with 1/2" x 3/8" weld-on step <ul style="list-style-type: none"> SI-series V-nose edge protectors are perfect for potato digger blades Casting #TF-106 SI-12HD 	2.17
SGT-12X1/2	1/2" x 12" Triangular-shaped segmented guard <ul style="list-style-type: none"> 3 segments are 4" long Perfect for welding to harrow tines or on pasture renovation equipment 	0.46



SI-12



SI-12HD

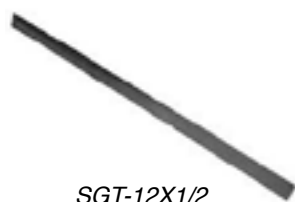

SGT-12X1/2

Weld-On Segmented Guards

Part#	Description	Weight
KTWS-01	9/16" x 6" Segmented Guard <ul style="list-style-type: none"> 4 segments are 1-1/2" long 	0.34
KTWS-02	3/4" x 6" Segmented Guard	0.49
KTWS-05	9/16" x 6" Fert. Knife Wear Shin	0.33
KTWS-06	3/4" x 1.96" Scraper Bit	0.17
KTWS-07		



KTWS-01

Subsoiler/Ripper



Acra-Plant V-Slice Inserts

Time-tested and improved V-slice inserts for just about any row crop planter or lister. Improve seed-to-soil contact in the toughest planting conditions with Acra-Plant V-slice technology. All Acra-Plant V-slice inserts either COME WITH hardware or use the Original Equipment hardware for ease of installation.

Acra-Plant V-slice openers that replace Original Equipment Seed Tube Guard/Inner Scrapers

Part #	Description	Weight
AP-001685	V-slice insert with pin/bolt White 6000 Series and later <ul style="list-style-type: none"> • Designed for replacement of OEM seed tube guard/inner scraper • Spring pin and bolt/nut provided with insert 	1.88
AP-001785	V-slice insert with pin/bolt John Deere & Kinze 2000 <ul style="list-style-type: none"> • Designed for replacement of OEM seed tube guard/inner scraper • Spring pin and bolt/nut provided with insert 	2.00
AP-001985XP	V-slice for John Deere 1700-series XP Row units <ul style="list-style-type: none"> • Designed for replacement of OEM seed tube guard • No hardware required, bayonet mount 	2.24
AP-001885	Kinze 3000 series V-slice opener <ul style="list-style-type: none"> • Designed for replacement of OEM seed tube guard/inner scraper • Uses same socket head cap screws as OEM scraper 	1.26



AP-001685



AP-001785



AP-001985XP



AP-001885

Replacement V-slice Inserts for Acra-Plant Planter/Lister assemblies

Part #	Description	Weight
AP-410000	Acra-Plant tandem blade opener slicing blade with bolt <ul style="list-style-type: none"> • Main replacement insert 10-C for Acra-Plant tandem blade opener 	2.20
AP-410100	Acra-Plant tandem blade rear opener slicing stub with J-bolt <ul style="list-style-type: none"> • Short (rear) replacement insert for Acra-Plant tandem blade opener and V-9 Acra-Plant opener for CaseIH 400-500 with offset discs 	1.01
AP-954141	V-slice lister opener with J-bolt, 7-C <ul style="list-style-type: none"> • Replacement insert for Acra-Plant lister opener AP-959600 	1.30



AP-410000



AP-410100



AP-954141

For complete descriptions of Acra-Plant No-Till planter/lister/drill enhancements, please see our Acra-Plant No-Till Catalog.



Acra-Plant®

V-SHOT

Insert Kit for JD XP Planters



Complete single-row kit including all hardware, liquid fertilizer hookup fitting and 1/4" plastic feed line "plug and play!!"

AP-1985V-SHOT

- ✓ ***V-Slice proven technology, improving seed-soil contact***
- ✓ ***Uniform and early emergence, eliminate seed roll-and-bounce***
- ✓ ***Apply starter fertilizer WHERE IT BELONGS, below the seed***



CALL FOR DEALER NEAREST YOU

800-798-1968

WWW.SHIELDAG.COM



MADE IN THE U.S.A.

Chrome Carbide General Application Edge Protectors

Part#	Description	Weight
AP-410601	IER3 slicing insert with pins <ul style="list-style-type: none"> • Replacement insert for Acra-Plant AP-009840 V-98 Opener • CaseLH 800-1200 planters • Casting #410601 	1.28
AP-410602	V51 slicing insert with pins <ul style="list-style-type: none"> • Replacement insert for Acra-Plant AP-034550 Opener • White 5100 and 5700 planters • Casting #410602 	1.04



Replacement V-slice Inserts for Acra-Plant Acra Drill Unit (ADU) and fertilizer attachments

Part#	Description	Weight
AP-A331100	ADU insert JDI3 with bolts/nuts for Acra Drill Unit <ul style="list-style-type: none"> • Replacement insert for Acra-Plant ADU • Casting # 331100 	1.88
AP-API4L	Acra-Place insert, 19978 and later, left hand <ul style="list-style-type: none"> • Replacement insert for Acra-Plant fertilizer openers • Casting # 691241 (L) 	1.89
AP-API4R	Acra-Place insert, 1997 and later, right hand <ul style="list-style-type: none"> • Replacement insert for Acra-Plant fertilizer openers • Casting # 691240 (R) 	1.89



For complete descriptions of Acra-Plant No-Till planter/lister/drill enhancements, please see our Acra-Plant No-Till Catalog.

All Acra-Plant V-slice attachments are MADE IN USA using the finest Acra-Tuff Chrome Carbide alloy for durability and long wear-life. Our foundry uses state-of-the-art equipment and quality control procedures to assure TOP QUALITY and LONG LIFE.

Acra-Plant Cultivator Points & Sweeps

Acra-Plant Acra-Tuff Alloy Points and Sweeps are made in USA and will wear 3–4 times longer than hardfaced high-carbon steel cultivator tools and up to 6 times longer than plain high-carbon tools! Acra-Plant points and sweeps will wear sharp and hold their shape throughout their long wear life. You'll reduce downtime, especially on really wide implements.

All cultivator tools come with mounting hardware

Standard Mount Field Cultivator Tools

Part #	Description	Weight
AP-871101	2-3/4" Field cultivator point, with hardware <ul style="list-style-type: none"> • 2 Holes on 2" shank hole spacing • Casting # 871101 	2.15



AP-871101

Part #	Description	Weight
AP-871201	2-3/4" Field cultivator point, with hardware <ul style="list-style-type: none"> • Hole and slot mounting accommodates 1-5/8" to 1-3/4" spacing • Casting # 871201 	2.20



AP-871201

Part #	Description	Weight
AP-871107	7" Field cultivator sweep, with hardware and wedge <ul style="list-style-type: none"> • Hole and slot for 1-5/8" to 2" shank hole spacing • Casting # 871107 	4.50



AP-871107

All of these points and sweeps come with mounting hardware



Cultivator Points/
Sweeps



Made in the USA



AP-860102



AP-860202



AP-860402



AP-860702

Danish Tine Points & Sweeps ("S" Tines)

Part#	Description	Weight
AP-860102	<ul style="list-style-type: none"> • 1" Spike with neoprene shim and hardware 	0.80
AP-860202	<ul style="list-style-type: none"> • 2-1/2" Goosefoot with neoprene shim and hardware • Single hole mounting • Casting # 860202 	1.10
AP-860402	<ul style="list-style-type: none"> • 4" Sweep with neoprene shim and hardware • (4"OK sweep), single hole mounting • Casting # 860402 	1.10
AP-860702	<ul style="list-style-type: none"> • 7" Sweep with neoprene shim hardware • (7" OK sweep), single hole mounting • Casting #860702 	2.12

Sweeps Designed for Kongskilde 3000-Series

Part#	Description	Weight
AP-861202	<ul style="list-style-type: none"> • 2-1/2" Sweep with hardware (no shim) • 2-hole mounting designed for Kongskilde 300-series (3500, 3800) 	1.70

NOTE: AP-861202 Kongskilde sweep comes with mounting hardware but does not include shim.

All of these points and sweeps come with a form-fitting neoprene shim and mounting hardware to assure perfect fit on your equipment



Adding Acra-Plant Chrome Carbide Components to your existing equipment will yield additional acres of wear life and reduced downtime.

Use Weld-On Points to repair worn parts or build your own custom tools.

OEM Replacement Pin-on Cultivator Points

Part#	Description	Weight
TF-130N	Orthman 164-043 point • Improved for 2005 with Chisel Nose to enhance penetration and wear life • Casting # TF130 or TF130N	2.85



AP-860102

See SECTION 4 of this catalog for all of our chrome carbide ripper & subsoiler points



MADE IN THE U.S.A.

Chisel Plow

Use 7018 welding rod or Low Hydrogen Wire to weld these parts. Consult factory for details.

Weld On Chisel Point



Part#	Description	Weight
TFN-1006	<ul style="list-style-type: none">• Heavy-duty chisel point, 4-3/4" long x 3" wide• Designed to weld on 3" twisted chisels, pocket underside to weld onto the end of chisel or fabricated spike• Casting #TFN1006	1.04

**Cultivators, Sweeps, Chisel Plows or Listers
Acra-Plant has solid chrome carbide points to help
you improve performance and add wear life for the
"Do-It-Yourself" farmer.**



Rod Weeder Points

Use Acra-Plant chrome carbide rod weeder points to improve the performance and wear life of your rod weeder.

Part#	Description	Weight
AP-890000	Calkins rod weeder point • Casting #890000	2.11
AP-890100	Flex King Rod Weeder Point • For Flex King, Miller/Morris and other large point rod weeders • Casting #890100	3.46



AP-890000



AP-890100

Chrome Carbide Points for Strip Till, Fertilizer & Chisel Plow Rigs

All of these points are designed to weld on fabricated bar stock and are slightly wider than the bar stock they are designed to fit, to provide maximum protection from wear. Use 7018 welding rod or Low Hydrogen Wire to weld these parts. Consult factory for details.

Part#	Description	Weight
717SM		1.06
DF1PM		1.78
DF1PM-PO		2.62
DF1ST		2.80



717SM



DF1PM



DF1PM-PO



DF1ST

**Building your own fertilizer or strip till rig?
We've got your point!**

Special Application



INNOVATION IN AGRICULTURE.

HD PRY-BARS

Our HEAVY-DUTY pry-bars are the hottest thing going for farm equipment dealerships & small fab shops. Take advantage of this hot selling pair of pry-bars today.

SPB-1 DOUBLE HOOK BAR

- Dimensions: 1x1x45"
- Weight: 13 Lbs



SPB-2 POINT BAR W/HOOK

- 7° double taper
- Dimensions: 1x1x23"
- Weight: 6.5 Lbs



- 5160 Chromium-Manganese
- Heat Treated & Tempered
- 150,000 psi Strength
- Made in the USA

ShieldAg pry-bars are manufactured in the USA, from fine-grained, double-rolled 5160 chromium-manganese steel that's heated and tempered for 150,000 psi strength, durability and toughness that can't be matched.

STRAIGHT FROM THE HEARTLAND



Learn more details at:
SHIELDAG.COM



Call for dealer nearest you
800-798-1968

Acra-Plant/ShieldAg Part Number Conversions

Catalog Number	Acra-Plant/ShieldAg Part Number	Description
11	AP-720011X	Drill Point
14	AP-729390	Drill Point
41	AP-700041	Fertilizer Point
42	AP-700042	Fertilizer Point OBSOLETE
44	AP-700044	Fertilizer Point
66	AP-729400	Drill Point
73	DNC-657D	Drill Point
73	DNC-657DEB	Drill Point
75	AP-729410	Drill Point
087	TFN-1010	Lister Point OBSOLETE
98	AP-729390	Drill Point
99	AP-729400	Drill Point
103	TF-103	Ripper Point
122	TF-122	Ripper Point
657	DNC-657D	Drill Point
8201	TF-820102	VPS Point
8202	TF-820202	VPS Point
52896	AP-801600	Shin Guard
300136	TF-129	Shin Guard
331100	AP-331100	V-Slice Insert
410601	AP-410601	V-Slice Insert
410602	AP-410602	V-Slice Insert
410901	AP-410901	V-Slice Insert OBSOLETE
500274	AP-708003	Wedge
691240	AP-API4R	V-Slice Insert
691241	AP-API4L	V-Slice Insert
700141	AP-700042	Fertilizer Point
705141	AP-705141	Chisel Point
720011	AP-720011X	Drill Point
800500	AP-800500	Ripper Point
800900	AP-800900	Ripper Point
801100	AP-801100	Ripper Point
801101	AP-801101	Ripper Point OBSOLETE
801200	AP-801200	Ripper Point OBSOLETE
860102	AP-860102	Danish Tine
860202	AP-860202	Goosefoot
860402	AP-860402	Sweep
860702	AP-860702	Sweep
861202	AP-861202	Goosefoot
861402	AP-861402	Sweep OBSOLETE
871101	AP-871101	Cult Point
871107	AP-871107	Sweep
871109	AP-871109	Sweep OBSOLETE
871201	AP-871201	Cult Point
890000	AP-890000	Rod Weeder
890100	AP-890100	Rod Weeder

Catalog Number	Acra-Plant/ShieldAg Part Number	Description
11CC	AP-720011X	Drill Point
164-037	AP-800102	Ripper Point
164-039	AG-8001-DF	Ripper Point
164-041	AP-800104	Ripper Point
164-043	TF-130N	Cult Point
5-919-606	AP-890000	Rod Weeder
657DEB	DNC-657DEB	Drill Point
657PO	AP-729410	Drill Point
657V	DNC-657V	Drill Point
715V	DNC-715V	Drill Point
716S	716S	Fertilizer Point
73CC	DNC-657D	Drill Point
73CC	DNC-657DEB	Drill Point
75CC	AP-729410	Drill Point
78CC	TF-150	Renovator Point OBSOLETE
8006-01	AP-800601	Ripper Point
8006-01W	AP-800601W	Ripper Point
809I	AP-720011X	Drill Point
809V	DNC-809V	Drill Point OBSOLETE
98CC	AP-729390	Drill Point
A11	AP-720011X	Drill Point
A14A	AP-729390	Drill Point
AG-7100-60	AP-710060	Drill Point
AG-7100-70	AP-710070	Drill Point
AG-7120-00	AP-712000	Drill Point
AG-8001-DF	AG-8001-DF	Ripper Point
AP-809-01	DNC-809V	Drill Point OBSOLETE
AP12	AP-691042	V-Slice Insert OBSOLETE
AP13L	AP-691041	V-Slice Insert OBSOLETE
AP13R	AP-691040	V-Slice Insert OBSOLETE
AG-809-01	DNC-809V	Drill Point
AP12	AP-691042	V-Slice Insert
AP13L	AP-691041	V-Slice Insert
AP13R	AP-691040	V-Slice Insert
AP14L	AP-API4L	V-Slice Insert
AP14R	AP-API4R	V-Slice Insert
APFC-1	AP-708041	Fertilizer Point
ARP1	AP-800401	Ripper Point
ASV1	AP-410901	V-Slice Insert OBSOLETE
ATC1	AP-820105	Cap OBSOLETE
ATP1	TF-820101	VPS Point
ATP2	TF-820102	VPS Point
ATP4	TF-820108	VPS Point
ATS1	TF-129	Shin Guard
ATW1	AP-820103	Wing OBSOLETE
ATW2	AP-820104	Wing OBSOLETE

Acra-Plant/ShieldAg Part Number Conversions

Catalog Number	Acra-Plant/ShieldAg Part Number	Description	Catalog Number	Acra-Plant/ShieldAg Part Number	Description
BJ3AFALL	AP-801400	Ripper Point	HK-1P	TF-150	Renovator Point OBSOLETE
BJ3ASPRING	AP-801300	Ripper Point	IER3	AP-410601	V-Slice Insert
BOP1	AP-800207	Ripper Point	IRP1	AP-800500	Ripper Point
BOP2	AP-801000	Ripper Point OBSOLETE	IRP2	AP-800900	Ripper Point
BRP1	AP-800601	Ripper Point	JDI3	AP-331100	V-Slice Insert
CAP1	AP-708041	Fertilizer Point	JDM2	AP-001785	V-Slice Insert
CCP-1	DNC-657D	Drill Point	JDSA	AP-957273	Seed Adapter
CCP-1	DNC-657DEB	Drill Point	JHZ1	AP-712000	Drill Point OBSOLETE
CCP4	AP-720011X	Drill Point	JRP1	AP-800601	Ripper Point
CEL1	AP-954141	V-Slice Insert	KMC1	AP-801500	Ripper Point OBSOLETE
CEO1	AP-410000	V-Slice Insert	KRP1	TF-122	Ripper Point
CES1	AP-410100	V-Slice Insert	KST2	AP-861202	Goosefoot
CP20	AP-800102	Ripper Point	KST4	AP-861402	Sweep OBSOLETE
CP5026	AP-801600	Shin Guard	KWRP1	AP-800601	Ripper Point
CP65	TF-65B	CaseIH Rasp	LRP1	AP-801200	Ripper Point OBSOLETE
CP66	TF-66RB	CaseIH Rasp OBSOLETE	MWRP1	AP-800800	Ripper Point
CT-3	TFN-1005	Chisel Point OBSOLETE	NHP1	AP-700041	Fertilizer Point
CUP1	AP-871101	Cult Point	NHP4	AP-700044	Fertilizer Point
CUP2	AP-871201	Cult Point	NHP5	AP700042	Fertilizer Point OBSOLETE
DNC4100	AP-410000	V-Slice Insert	ORP1	AP-800102	Ripper Point
DNC4141	AP-954141	V-Slice Insert	ORP2	AP-800104	Ripper Point
DNC559T	TF-123	Ripper Point	ORP3	AP-801100	Ripper Point
DNC-757I	AP-720011X	Drill Point	ORP4	AP801101	Ripper Point OBSOLETE
DNC8001	TF-122	Ripper Point	RWP1	AP-890000	Rod Weeder
DNC-809I	AP-720011X	Drill Point	RWP2	AP-890100	Rod Weeder
DNC-827P	AP-710070	Drill Point	SAB1	AP-300039	ADU Spring Bar
DNC-829	AP-710060	Drill Point	SI-12HD	SI-12HD	Edge Guard
DST1	AP-860102	Danish Tine	SR9175	TF-66RB	CaseIH Rasp OBSOLETE
DST2	AP-860202	Goosefoot	SR9336	TF-65B	CaseIH Rasp
DST4	AP-860402	Sweep	SSPL	AP-880001	Soil Saver OBSOLETE
DST7	AP-860702	Sweep	SSPR	AP-880000	Soil Saver OBSOLETE
DSZ10	AP-729410	Drill Point	TF CC 13	TF-CC13	Knife Edge OBSOLETE
DSZ11	AP-720011X	Drill Point	TF CC 13 1	TF-CC13-1	Knife Edge OBSOLETE
DSZ6	AP-710060	Drill Point	TF102	TF-102	Cult Point OBSOLETE
DSZ7	AP-710070	Drill Point	TF105	AP-729410	Drill Point
DSZ8	AP-710080	Drill Point	TF106	SI-12HD	Edge Guard
DSZ9	AP-729390	Drill Point	TF111	AP-710060	Drill Point
E1	AP-720011X	Drill Point	TF123	TF-123	Ripper Point
E4	AP-729390	Drill Point	TF130	TF-130N	Cult Point
E6	AP-729400	Drill Point	TF130N	TF-130N	Cult Point
FAD2	AP-699014	Chrome Wheel OBSOLETE	TF132	AP-729390	Drill Point
FAD3	AP-699114	Chrome Wheel OBSOLETE	TF148	TF-148	Golden Spike OBSOLETE
FCP1	AP-705141	Chisel Point	TF150	TF-150	Renovator Point OBSOLETE
FCS11	AP-871111	Sweep OBSOLETE	TF238 12	342-JD-238	Ripper Point
FCS7	AP-871107	Sweep	TF278 12	342-JD-278	Ripper Point
FCS9	AP-871109	Sweep OBSOLETE	TF66RB	TF-66RB	CaseIH Rasp OBSOLETE
GRP1	AP-800700	Ripper Point	TF700041	AP-700041	Fertilizer Point
			TF700044	AP-700044	Fertilizer Point

Acra-Plant/ShieldAg Part Number Conversions

Catalog Number	Acra-Plant/ShieldAg Part Number	Description	
TF800102	AP-800102	Ripper Point	
TF800104	AP-800104	Ripper Point	
TF800207	AP-800207	Ripper Point	
TF8006-011	TF-8006-011	Ripper Point	
TF8006-011W	TF-8006-011W	Ripper Point	
TF800700	AP-800700	Ripper Point	
TF801300	AP-801300	Ripper Point	
TF801400	AP-801400	Ripper Point	
TF82010 1	TF-820101	VPS Point	
TF820102	TF-820102	VPS Point	
TF820107	TF-820107	VPS Point	
TF820108	TF-820108	VPS Point	
TFN1005	TFN-1005	Chisel Point	OBSOLETE
TFN1006	TFN-1006	Chisel Point	
TFN1010	TFN-1010	Lister Point	OBSOLETE
TFRP1	AP-801400	Ripper Point	
TSRP1	AP-801300	Ripper Point	
WAW1	AP-034550	Wedge	
WH11	AP-410602	V-Slice Insert	
Z10	AP-729410	Drill Point	
Z11	AP-720011X	Drill Point	
Z6	AP-710060	Drill Point	
Z7	AP-710070	Drill Point	
Z8	AP-710080	Drill Point	

Casting Number	Acra-Plant/ShieldAg Part Number	Description
809V	AP-720011XV	Drill Point
DNC-809V	AP-720011XV	Drill Point
705042	AP-795042	Chisel Plow Fertilizer Point
AP-800105	AP-800106	Strip Till Point
BJ3AFall	AP-505200	Ripper Point
BJ3ASpring	AP-503300	Ripper Point
1685	AP-001685	V-Slice
1785	AP-001785	V-Slice
1785VS	AP-001785VS	V-Slice
1885	AP-001885	V-Slice
1985XP	AP-001985XP	V-Slice
1985XPVS	AP-001985XPVS	V-Slice
164-050	AP-800106	Strip Till Point
164-054	AP-800106	Strip Till Point
164-057	AP-800106	Strip Till Point

All Acra-Plant Chrome Carbide Products are MADE IN USA using the finest Acra-Tuff alloy for durability and long wear-life. Our foundry uses state-of-the-art equipment and quality control procedures to assure TOP QUALITY and LONG LIFE.



STRAIGHT FROM THE **HEARTLAND** SHIELDAG.COM



CALL THE DEALER **NEAREST YOU**

PHONE: (620) 662-7221 (800) 798-1968

FAX: (620) 662-7482

MAILING: PO BOX 687 • HUTCHINSON, KS 67504

SHIPPING: 950 SCOTT BLVD • SOUTH HUTCHINSON, KS 67505

