

# ShieldAg/ABM Milo Guards

ShieldAg/ABM Milo Guards are manufactured in Kansas and are designed for most popular makes and models of standard small grain headers, **INCLUDING DRAPER HEADERS.**

We stock the **ORIGINAL ORANGE ABM** Milo Guards. Make sure you are getting **the only Milo Guards Made in USA—the ORANGE one!**

- Look for ORANGE grain saver boots, a great optional feature
- Our tine wires are made of high quality heat-treated spring steel
- Our construction is heavy-duty for extreme applications

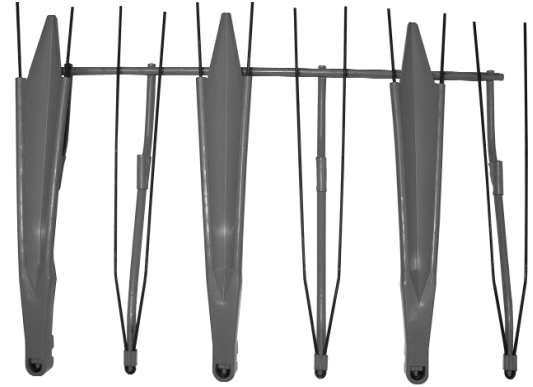

ShieldAg will have your ABM Milo Guard Fall 2010 pricing program in your hands by June 1st, 2010.

The **ORIGINAL ABM Milo Guard** line has been expanded to work on more draper headers.

Our 2010 Milo Guard Program will **INCLUDE** a new series designed for the John Deere 600-series Flex Header. See complete descriptions below.

## Milo Guards for most standard small grain headers

Part #	Description	Weight Lbs
FG-077	7 Point Section	4.63
FG-087	8 Point Section	5.38
JDF-010	C-Clasp	0.08
K11-001	C-2 Clasp	0.09
WND-002	H-Clip	0.07
WND-004	H-3 Clip	0.07
WND-103	H-4 Clip	0.07
11X-1308	Z-Clip	0.12
11G-1301	Tine Clip	0.02
11G-1401	Guard Point Clip	0.03
11X-3202	Tine Wire, high strength spring steel	0.12
ABM-2005	Orange UHMW plastic grain saver boot	0.16

*On standard headers, we recommend installing grain saver boots on every other set of tine wires to increase grain savings and help keep the wires out of the sickle.*

## Milo guards for John Deere draper headers and John Deere 600-series rigid platforms

*NOTE: These milo guards fit over standard length guard points on 4" spacings*

Part #	Description	Weight Lbs
ABM-D-6	6 Point Section, 2' overall width per section	3.49
ABM-D-1J	John Deere Draper Clip, 2 required per section	0.07
JDF-010	C-Clasp, 2 required per section	0.08
ABM-2005	Orange UHMW plastic grain saver boot	0.16

*On draper headers, we recommend installing grain saver boots on every set of tine wires to increase grain savings and help keep the wires out of the sickle.*

## Milo guards for other makes of draper headers

Part #	Description	Weight Lbs
ABM-D-6	6 Point Section, 2' overall width per section	3.49
ABM-D-1	Draper Clip, 2 required per section	0.07
JDF-010	C-Clasp, 2 required per section	0.08
ABM-2005	Orange UHMW plastic grain saver boot	0.16

*On draper headers, we recommend installing grain saver boots on every set of tine wires to increase grain savings and help keep the wires out of the sickle.*

# Bolt & Nut Boxed Sets and Bulk Hardware

All hardware is certified and MADE IN USA.

Buy in Bulk and Save!

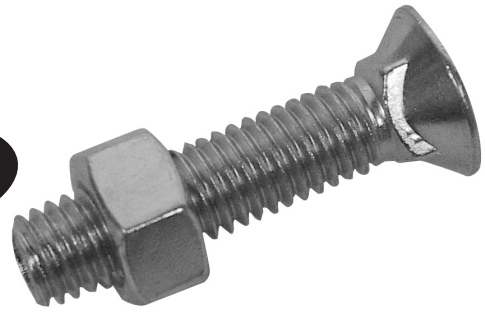

**Order Bolts & Nuts with your V-Blades, Sweeps or Chisels & Get 10% Off the Hardware!**

## Plated Grade 5 Plow Bolts with Nuts and Bulk Bolts

Part # 500	Bolt Size	Bolt Head Size	Nut Style	Weight Per Box	Nut + Bolt Box Qty	Bulk Bolt P/N	Weight per
2-2	3/8 x 1-1/4	3/8	Hex nut	5.8	100	Z2-2	20
2-3	3/8 x 1-1/2	3/8	Hex nut	6.3	100	Z2-3	23
2-4	3/8 x 1-3/4	3/8	Hex nut	6.8	100	Z2-4	26
3-2	7/16 x 1-1/4	7/16	Hex nut	4.4	50	Z3-2	29
3-3	7/16 x 1-1/2	7/16	Hex nut	4.8	50	Z3-3	31
3-4	7/16 x 1-3/4	7/16	Hex nut	5.3	50	Z3-4	38
3-7	7/16 x 2-1/2	7/16	Hex nut	6.3	50	Z3-7	49
4-2	1/2 x 1-1/4	1/2	Hex nut	6.25	50	Z4-2	37
4-3	1/2 x 1-1/2	1/2	Hex nut	6.5	50	Z4-3	43
4-3H	1/2 x 1-1/2	1/2	Heavy Hex	7.5	50	Z4-3	43
4-3JH	1/2 x 1-1/2	1/2	Heavy Jam	6.5	50	Z4-3	43
4-4	1/2 x 1-3/4	1/2	Hex nut	7	50	Z4-4	49
4-4H	1/2 x 1-3/4	1/2	Heavy Hex	7.75	50	Z4-4	49
4-4JH	1/2 x 1-3/4	1/2	Heavy Jam	7	50	Z4-4	49
4-6	1/2 x 2-1/4	1/2	Hex nut	8	50	Z4-6	59
4-6H	1/2 x 2-1/4	1/2	Heavy Hex	8.5	50	Z4-6	59
4-7	1/2 x 2-1/2	1/2	Hex nut	9	50	Z4-7	68
4-7H	1/2 x 2-1/2	1/2	Heavy Hex	9.5	50	Z4-7	68
4-8	1/2 x 2-3/4	1/2	Hex nut	9.2	50	Z4-8	73
4-8H	1/2 x 2-3/4	1/2	Heavy Hex	9.7	50	Z4-8	73
4-9	1/2 x 3	1/2	Hex nut	9.5	50	Z4-9	81

### Specialty Bolts with Nuts

H2-3	3/8 x 1-1/2	7/16	Hex nut	5.9	100	ZH2-3	28
H3-4	7/16 x 1-3/4	1/2	Hex nut	5.9	50	ZH3-4	44
H3-7	7/16 x 2-1/2	1/2	Hex nut	7	50	ZH3-7	55

BOLTS without NUTS may be ordered in Bulk lots of 500ea

**Call us for all your hardware needs!**

## Plated Grade 5 Hex Nuts



Part #	Nut Size	Style	Wrench Size	Weight per 100	Weight per 500
N2	3/8"-16	Hex	9/16	1.9	9.4
N3	7/16"-14	Hex	11/16	3.1	15.6
N4	1/2"-13	Hex	3/4	3.6	18.0
N4H	1/2"-13	Heavy Hex	7/8	6.2	31.0
N4JH	1/2"-13	Heavy Jam	7/8	3.4	17.0
N4J	1/2"-13	Jam	3/4	2.6	13.0

NUTS may be ordered in Bulk lots of 100ea or 500ea

# Crustbuster Replacement Parts

Part #	Description	Weight Lbs
KB-1	Double End Point	1.45
KST-1	Shank	7.75



## ShieldAg Pry Bars

ShieldAg pry-bars are manufactured from the finest chromium spring steel available. This material is fine-grained double-rolled 5160 chromium-manganese steel that is heat-treated and tempered for strength, durability, and toughness that cannot be matched by the cheap imported spring steels available.

At ShieldAg, we use only the highest quality materials in the manufacture of your tillage tools. Same with this pry-bar — it's made of the material that wrecking bars used to be made of — 100% made in USA. **Use it and abuse it with pride.**



Part #	Weight Size	Lbs
SPB-1	1 x 1 x 45" Double Hook Bar	13.00
SPB-2	1 x 1 x 23" Point Bar with 7° Taper	6.50

## Harrow Tynes

ShieldAg stocks the most popular harrow tynes and orders non-stock tynes upon request. Ask your Territory Manager for details.

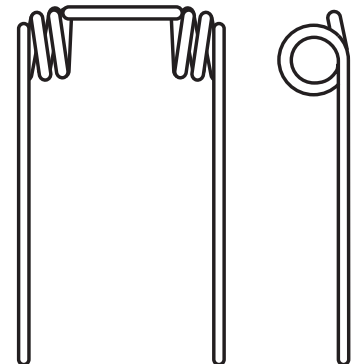

Part #	Description	Length	Width	Wire	Weight Lbs
149781	Nobel Harrow Tyn	11-1/2"	7-1/2"	0.375	2.30
24781	Nobel Harrow Tyn, dog leg	15-19/32"	7-1/2"	0.375	2.48
136767	John Deere Harrow	12-1/8"	7-3/8"	0.375	2.30

NOTE: Other Harrow Tynes available upon request. Lead times vary. All orders subject to boxed quantity minimums.